

PFAライニング・バルブ

PFA Lined Valve



Lined ball valve

Size	15mm~300mm (0.5"~12")
Working pressure	0.1mbar~16 bar
Temperature range	-20° C ~ 200° C according to working conditions, other temperatures on request.
Design and Manufacture	API 608 DIN 3357 JIS B2071
Face to Face	ASME B16.10 DIN 3202 JIS B2002
Flange Ends	ASME B16.5 DIN 2532 JIS B2212
Visual Inspection	MSS Sp54
Testing	API 598 DIN 12569 JIS B2003
Pressure & Temperature	ASME B16.34
Operator Type	Lever/ Gear/ Pneumatic/ Electric
Spark testing	14kv

 **SANKO METAL CO., LTD**

三幸金属株式会社

● 各部名称
Disassembled figure

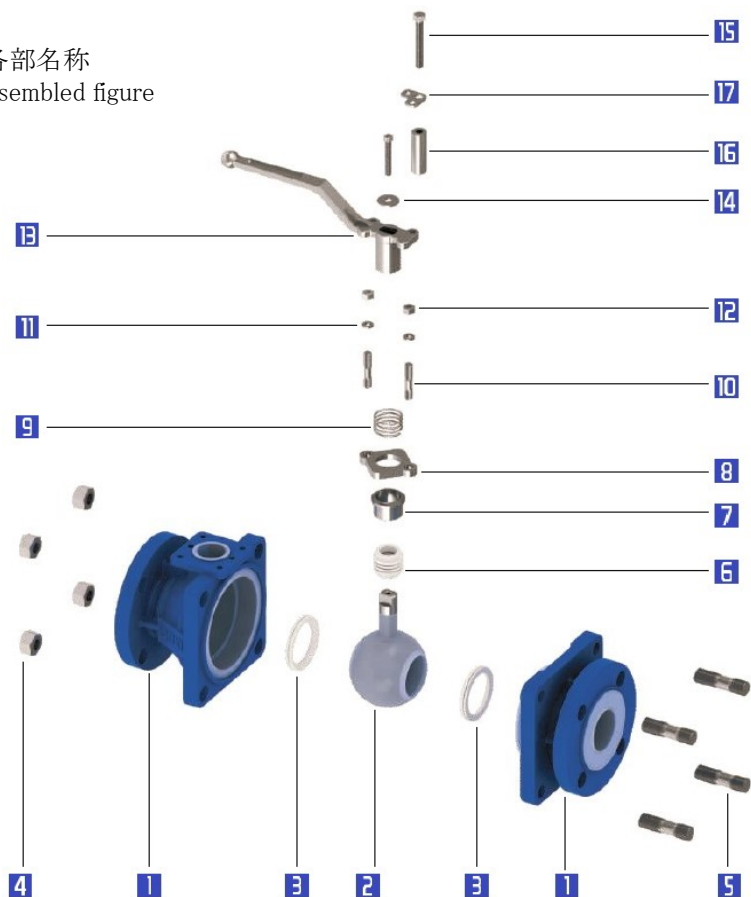

No	Description	Qty.	Materials
1	Body	2	Carbon Steel+PFA/FEP/ETFE
			Stainless Steel+PFA/FEP/ETFE
2	ONE-PIECE BALL	1	Ductile Iron+PFA/FEP/ETFE
			Carbon Steel+PFA/FEP/ETFE
3	SEAT RING	2	Stainless Steel+PFA/FEP/ETFE
4	STUD BOLT	4	Ductile Iron+PFA/FEP/ETFE
5	NUT	4	Carbon Steel+PFA/FEP/ETFE
6	PACKING MATERIAL	1	Stainless Steel+PFA/FEP/ETFE
7	SHAFT SLEEVE	1	Ductile Iron+PFA/FEP/ETFE
8	GLAND	1	PTFE
9	ANTI-STATIC SPRING	1	Stainless Steel
10	STUD BOLT	2	Stainless Steel
11	WASHER	2	Stainless Steel
12	NUT	2	Stainless Steel
13	HANDLE	1	Stainless Steel
14	WASHER	2	Stainless Steel
15	BOLT	2	Stainless Steel
16	LEVER STOP	1	Stainless Steel
17	LOCKER	1	Stainless Steel

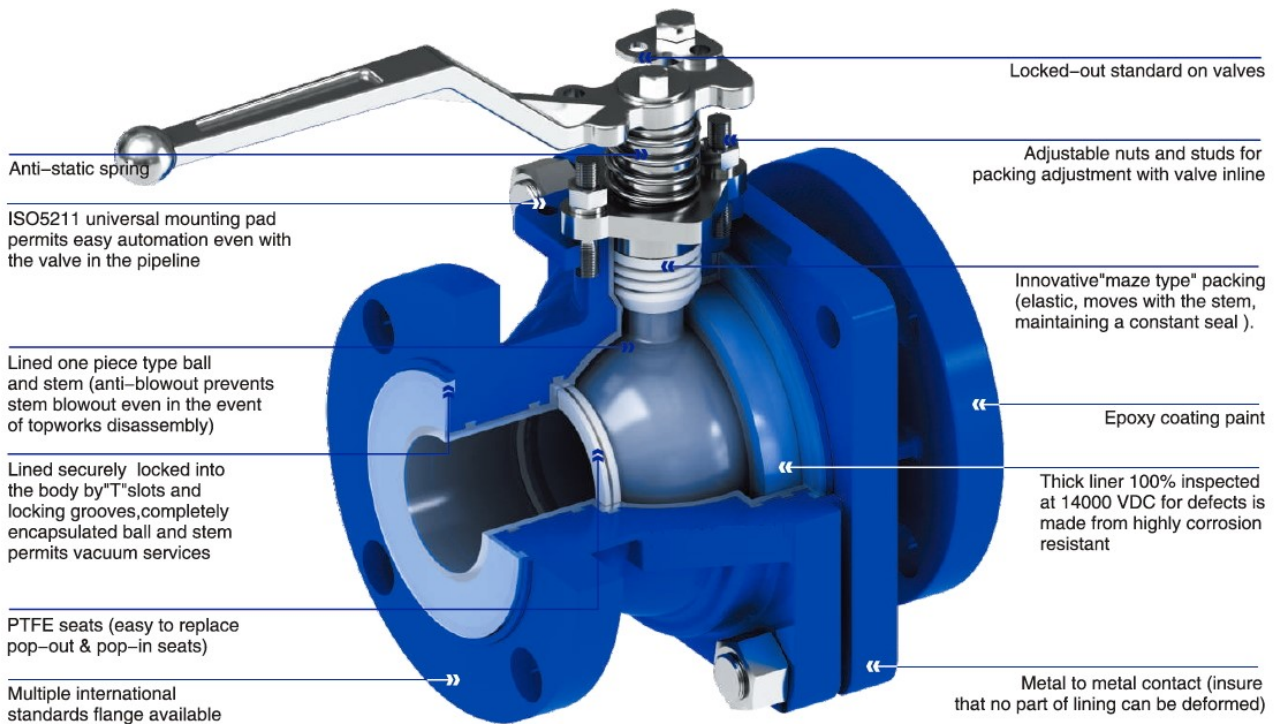

三幸金属株式会社
SANKO METAL CO., LTD

本社
Head Office 〒550-0004 大阪府大阪市西区靱本町1丁目16番17号
1-chome 16-17, Utsubohonmachi, Nishi-Ku, Osaka-City
, Osaka, 550-0004
Tel: 06-6441-6431 Fax: 06-6441-6548

工場
Factory 〒639-0241 奈良県香芝市高188-1
188-1, Taka, Kashiba-City, Nara, 639-0241
Tel: 0745-78-4552 Fax: 0745-78-4562

ホームページ
Home Page <http://www.sanko-metal.co.jp>

- 本カタログ記載の内容については予告なく変更することがあります。
There is a case that the contents of this catalogue will be revised without any notice.