

OUTLINE

FW9000NN Series is the successor to the well received and widely used FW-9000 series for its reliability and variety of long term application.

Using the most of reliable, durable and highly accurate mechanism of FW-9000, **FW9000NN** has become more reliable and user-friendly by introducing up-dated electronics etc (SIL2 compatible).

Consequently, **FW9000NN** has the interchangeability with the current FW-9000 series in terms of installation methods and interfaces with other equipment.

Its noise resistivity and lightning protection performance have been improved significantly.

The intensified automatic self-diagnosis and self-adjustment functions have made **FW9000NN** more user friendly.

Including ATEX certified version intended for use in potentially explosive atmosphere **FW9000NN** is ready to serve world-wide users.

APPLICATIONS

- For bonded tanks
- For LPG, LNG, Petroleum, Fuels, Water supply and Sewage systems, Chemicals, Power Plants, Food and Beverages.
- For versatile applications such as various kinds of liquid measurement, 2-liquids interface, a-point-measurement of liquid density, multi-points measurement of liquid density for profile presentation.

FEATURES

Those items marked as ☆ are added or improved features from existing models.

- ☆ For bonded tanks
 - The increased noise resistivity and lightning protection assure you reliable operation as complying with superb level 4 or more stipulated in IEC61000-4,5.
 - Protection from direct lightning (Option)
- ☆ Complying with RoHS requirements.
- ☆ Having the same dimensions and materials as existing models, FW9000NN is compatible to Japanese explosion-proof requirements and is interchangeable with existing FW-9000 to make replacement easy.
- ☆ Parameters can be set without opening housing with 4 magnet sensors attached to the indicating windows.
- ☆ Compatible with wide range of power supply from 100 to 240 VAC, 50/60Hz.
- ☆ Standardized 2 sizes of measuring drums cover wide measuring ranges from small to gigantic tanks.
- Eco-friendly low power consumption as small as Max. 25VA.
- Covers high design pressure up to 3.0 MPa.
- Electronic circuits are installed in the electric compartment which is completely isolated from drum compartment.



- Can be connected to the existing spot type and multipoint averaging temperature sensors.
- Precision stepping motor control with micro processor has realized amazingly accurate measurement.
- Highly reliable operation with powerful self-diagnosis functions (SIL2).
- High durability with non-contact type balancer without using slip ring.
- In has addition to the high-speed serial data communication, FW9000NN have various communication tools which are compatible to TOKYO KEISO's existing well-established transmitters. Therefore, FW-9000NN serves with ease for your renovation and replacement of the existing tank monitoring system.
- In combination with DIR110NN series, Max. 6 contact signals transmitted between field and control room. Monitoring and control of equipments around the tank yard are also possible in addition to liquid level measurement.
- 4 to 20 mA signals such as pressure signal can be digitalized and retransmitted.
- Analog 4 to 20mA signals such as level and temperature can be output additionally to meet with high speed data processing carried by host computers.

MODEL CODE

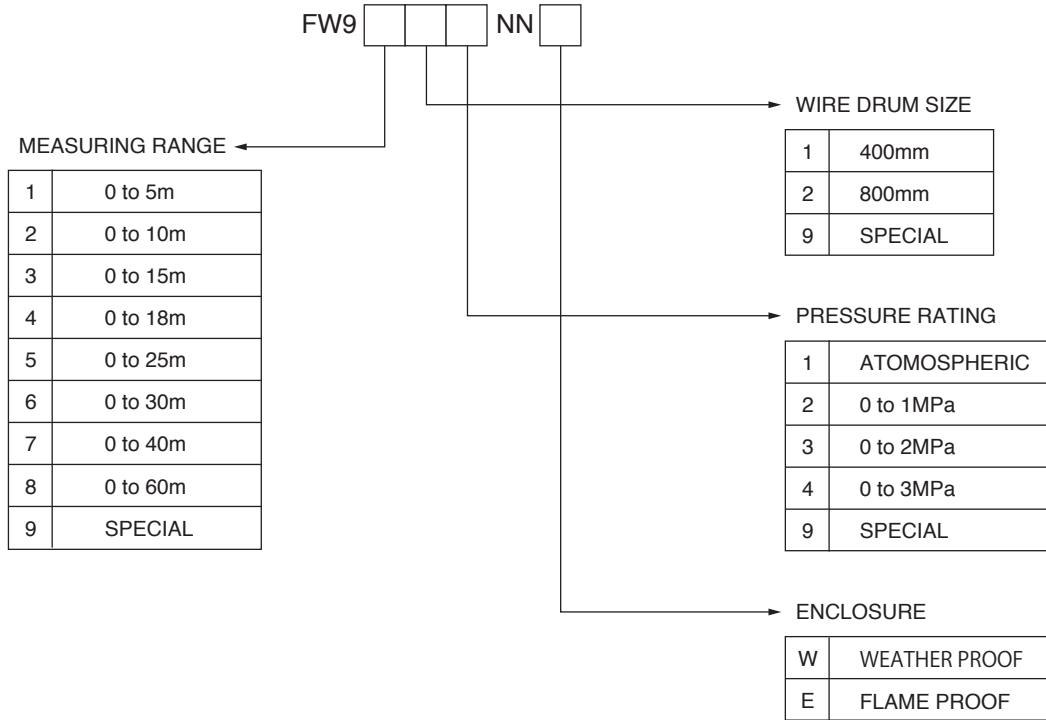

OPERATING PRINCIPLE

A very thin measuring wire B is wound onto measuring drum C having 400 mm/r or 800 mm/r precisely machined spiral groove.

Measuring drum C is connected to Driving shaft F through magnet coupling D, E and rotates forward and backward according to movement of gear-down unit J, K and stepping motor N. A worm gear J, which is located on the same axis as Driving shaft F, is connected to Driving shaft F through Spring I.

By this arrangement, tension onto Measuring wire B can be precisely detected by measuring distortion of Spring I by Balancer G. A Displacer A, of which density is higher than that of liquid to be measured, is connected to one end of Measuring wire B. The weight of Displacer A always gives downforce tension to Driving shaft F. In normal measurement condition, Stepping motor N is controlled by signal from Balancer G to give Measuring wire B a slightly less and constant tension than the weight of Displacer A. In this way, Displacer A always follows liquid surface with stable draft line.

Thus, rotating angle of Measuring drum C which corresponds to length of unwound Measuring wire B represents height of liquid in tank.

By adjusting the control level of tension T onto measuring wire B, interface of two liquids having different density can also be measured. Also, by sinking displacer into liquid and measuring the tension T onto measuring wire B, the liquid density can be detected and measured.

In FW9000NN, signal from Balancer G is fully digitalized. Stepping motor N, having high resolution, is controlled by Microprocessor unit H. This digitalized servo operation system offers high liquid following capability and stability in operation compared to existing analog control method.

The angle of Measuring drum rotation is obtained from the number of steps of Stepping Motor N. This remarkably improves the resolution of liquid level measurement of 0.025 mm.

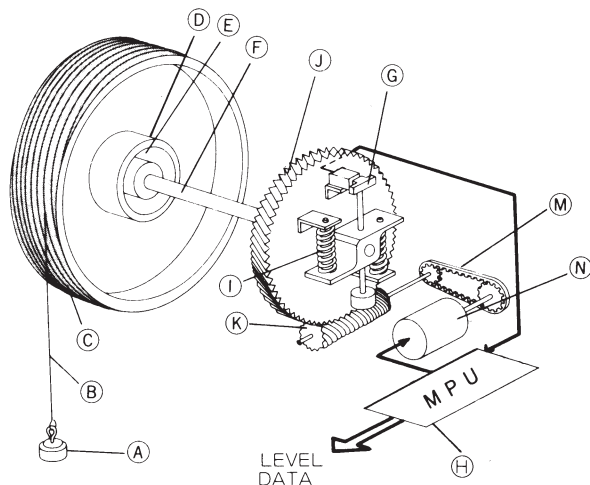

STANDARD SPECIFICATION

Mechanical specification

- Liquid level detection : Digitally controlled balancing servo consisting of small size displacer, measuring wire and wire drum
- Displacer : Dia. ϕ 140, ϕ 110, ϕ 90, ϕ 70, ϕ 50, ϕ 30
Mass 250g (Standard)
Material SUS304, SUS316, SUS316L, MA (Equiv. to Hastelloy*), PTFE, others
- Measuring wire : Standard SUS316 (ϕ 0.2, single)
Option *1 MA (Equiv. to Hastelloy) (ϕ 0.3, single)
FEP covered (ϕ 0.6, stranded core)
- *1 Small type wire drum may be unable to be used in case of measuring wires other than standard (ϕ 0.2) even in short measuring range. Consult factory for details.
- Wire drum size : 400 mm/r (FW9□□1□NN□)
800 mm/r (FW9□□2□NN□)
- Tension detection : By using perfect Non-contact magnetic field response type Hall element sensor
- Driving motor : High resolution type stepping motor
- Drive shaft sealing : Strong magnet coupling

- Measuring range

0~5m	(FW91□□NN□)	*2
0~10m	(FW92□□NN□)	*2
0~15m	(FW93□□NN□)	*2
0~18m	(FW94□□NN□)	*2
0~25m	(FW95□□NN□)	*2
0~30m	(FW96□□NN□)	*2
0~40m	(FW97□□NN□)	*3
0~60m	(FW98□□NN□)	*3
Special	(FW99□□NN□)	*3

- *2 Small size drum (400 mm/r, FW9□□1□NN□) or large size drum (800 mm/r, FW9□□2□NN□) is applicable.
- *3 Large size drum (800 mm/r, FW9□□2□NN□) is applicable.

- Temp. range : Liquid -200 to +300°C
Ambient -40 (-20 to +55°C TIIS)
(Temperature of main body)
Under the conditions where, the liquid and the moisture inside the wire drum room shall not freeze over, nor adhere.
*Not suitable for the use environment where the mass of displacer changes by the attachment of liquid.

● Operating pressure :

Prees.	Op. press. (MPa)	MODEL	Material of pressurized part
Low press.	ATM	FW9□□□1NN□	AC2A, SCS13, SCS14
High press.	0 ~ 1	FW9□□□2NN□	SCS13, SCS14
	0 ~ 2	FW9□□□3NN□	SCS13, SCS14
	0 ~ 3	FW9□□□4NN□	SCS13, SCS14

- Accuracy* (Indication and digital output) :
 - 1) Liquid level measurement \pm 1.0mm (Refer to factory for detail)
 - 2) Interface measurement in case of density difference of 0.2 g/cm³ \pm (2.7) mm
 - 3) Density measurement \pm 0.01g/cm³

* Under reference conditions.

- Process connection : Flange
 - Flange size 3", 4", 5", 6" or other specials
(Horizontal movement of displacer for tank height shall be considered for decision of flange size)
 - Flange rating JIS5K/10K/20K/30KRF, ANSI 150/300, JPI 150/300, Others

- Displacer guiding : Standard : By stand pipe
Option : Non guide *4
By guide wire *4
Special *4

*4 : Specified accuracy not applicable. Consult factory for further details.

- Displacer horizontal movement :

For small size drum
(400 mm/r, FW9□□1□NN□)
for 1 m liquid level movement

$\Delta a = 2.5\text{mm}, 1.9\text{mm}, 1.4\text{mm}, 1.125\text{mm}$

For large size drum
(800 mm/r, FW9□□2□NN□)
for 1 m liquid level movement

$\Delta a = 1.25\text{mm}, 0.95\text{mm}, 0.7\text{mm}, 0.57\text{mm}$

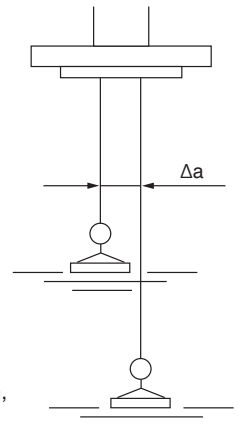

- Construction : Weather proof (FW9□□□NNW) or Flameproof ExdIICT6 (FW9□□□NNE) (TIIS certification No. TC14583)
- Protection class : IEC60529 (JIS C0920) IP66/67
- Functional Safety : SIL2 (IEC 61508)

*Hastelloy: Trade mark of Haynes International Inc.

ELECTRONICS AND SOFTWARE SPECIFICATION

● Signal

1) External input

Besides normal level measurement by FW9000NN, the following external devices can be connected to FW9000NN. Data from such external instruments are digitalized and transferred to control room through serial data signal:

a. Temperature sensors

(Temperature conversion range : -200 to +320°C)

- 1) Pt100Ω spot temp. sensor (TS type of Tokyo Keiso or equivalent)
- 2) Average temp. sensor (ATM type of Tokyo Keiso or equivalent)
- 3) Multi-spot average temp. sensor (ATS type of Tokyo Keiso or equivalent)

b. Analog signal

4 to 20mA, 1 point (Input resistance 250Ω)

2) External output :

a. Serial communication signal for receiver in for remote control room, Refer to ◆ COMMUNICATION FUNCTION for further details.)

b. Serial data coded output for explosion-proof tank side receiver (Electric)

c. Contact output

Number of contacts : 2

Configuration : SPST(1a or 1b)

d. Analog output

4 to 20 mADC ×2 (Level and Temperature)

conversion accuracy ± 0.5% F.S.

HART (Ver.7) available for either one channel.

● Alarm monitoring :

2 Points of liquid level alarms or temperature alarms

Max.6 points when tank side indicator (DIR110NN series) is used.

When input signals exceed set points :

- 1) Specified alarm message is indicated on LCD.
- 2) Specified bit of serial output is "ON".
- 3) Assigned open collector output is actuated.

● Control and parameter setting :

All parameters can be set by the following procedures:

- 1) Dialogue type setting with magnetic sensor on indicator using Arrow mark.
The registered password allows parameter settings for security reason.
(Control and parameter setting are possible without opening housing cover with power "ON".)
- 2) Parameters are presettable through 2-way data communication from remote control room.
- 3) Dialogue type setting by tank side indicator (DIR-110N)

● Contents of control :

Liquid level, liquid interface, density, hoisting, lowering, stoppage etc of float

● Contents of parameter setting :

Hoisting (Maximum, Minimum), Adjustment of level indication, Displacer response PID, Alarm set point / Reset span / Alarm action / Relay allotment (Level, Temperature), Connection thermometer classification, Point changing of temperature element, Type of external input, etc.

● Self-diagnosis function

Error status Indication of status LCD	Diagnosis
1	Motor error
2	Under tension
3	Over tension
4	Balancer signal not in order
5	Repeatability error
6	Burn-out of temperature wire
7	Temperature scale over
8	Displacer control error
9	4 to 20 mA scale over
A	Non-volatile memory error
B	Sensor communication error
C	Density measurement error
E	Slit sensor error
G	Internal error

● Indication part

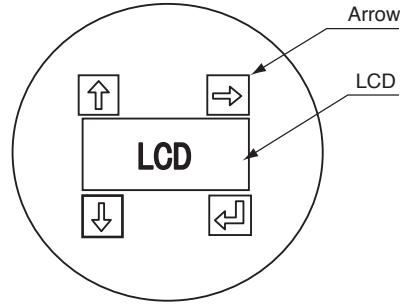

● Details of LCD presentation

• Operation mode

Level indication part (7 digits)

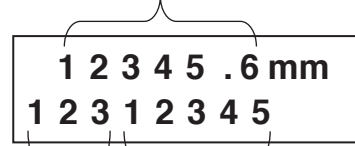

Status indication (3 digits)
(Error motor control state of displacer)

Data indication (5 digits)
(Temperature etc.)

• Parameter mode

Data indication (7 digits)

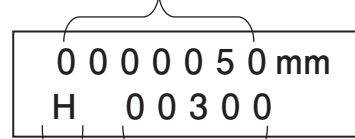

Register indication
(hold, input, adjustment)

Code indication (5 digits)
(hold, input, adjusted data)

- Cable entry : Standard G(=PF) or NPT female (Flameproof cable glands available as option)
- Size 3 × 3/4 inch + 1 × 1 inch

- Cable termination : Plug type terminal connection

- Power supply : 100 to 240 VAC, 50/60Hz

- Power consumption : Max. 25VA

- Arrester : Provided as standard

DIMENSION AND MASS

Small size drum, Low pressure type

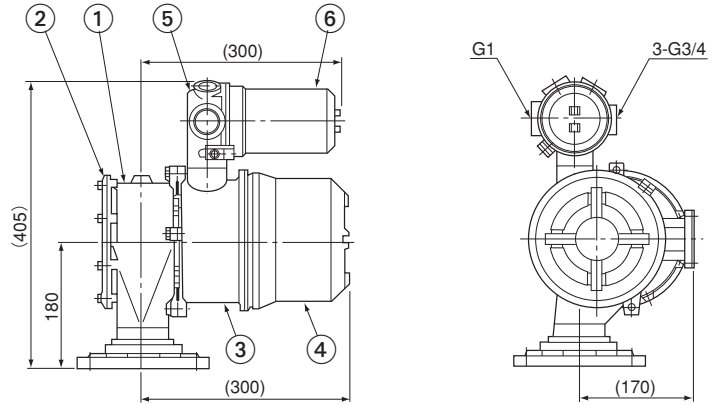

Small size drum, High pressure type

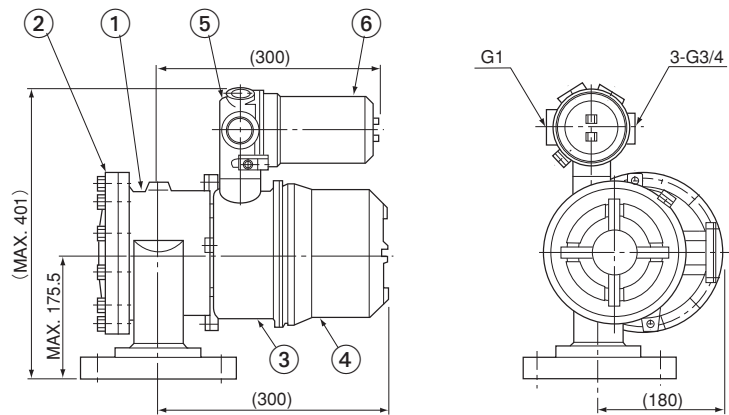

Large size drum, High pressure type

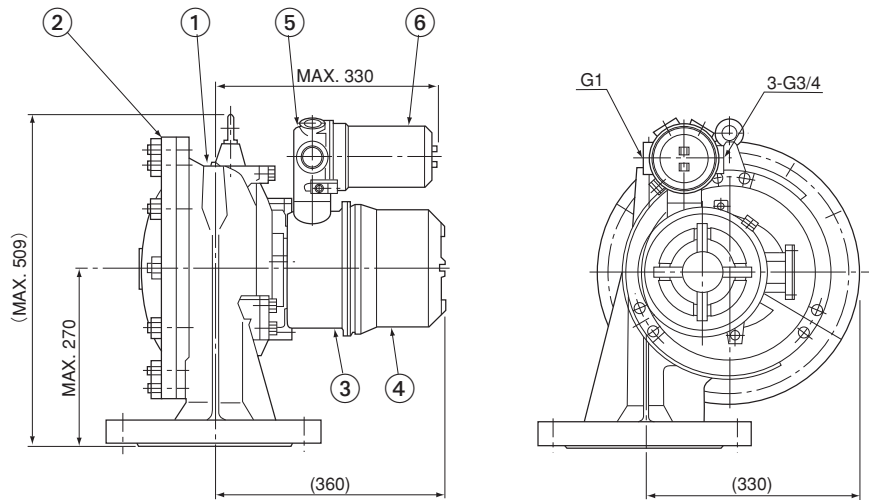

No.	Description
1	Wire drum compartment
2	Drum compartment cover
3	Electric compartment
4	Electric compartment cover
5	Terminal box
6	Terminal box cover

Wire drum compartment material	Wire drum size	
	Small	Large
AC2A	16kg	—
SCS13/14	35kg	90kg

INSTALLATION

Following examples show how to install the instruments on cone-roof tank, floating roof tank and sphere tank using stand pipes.

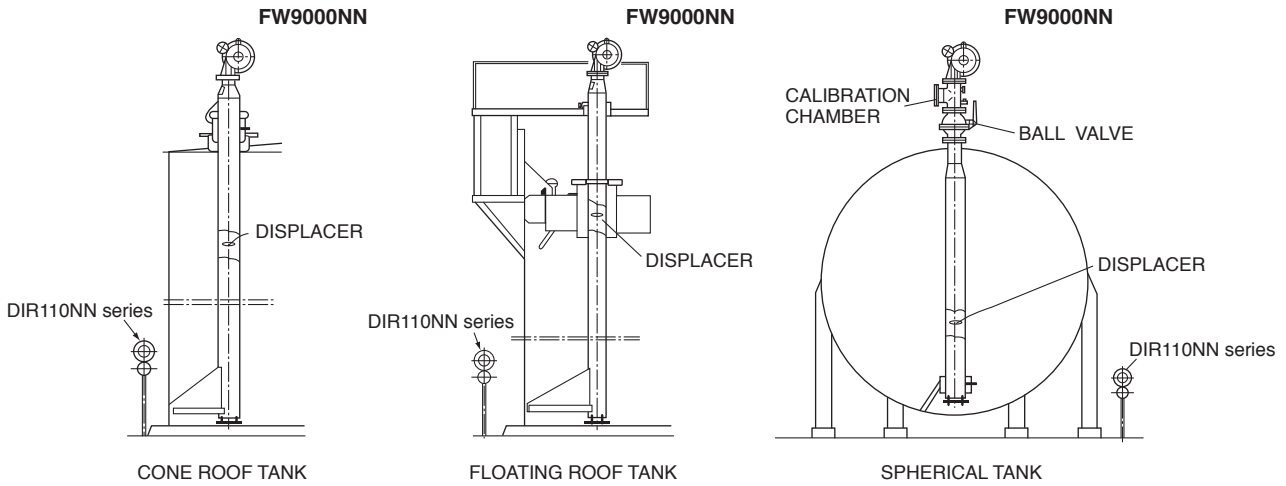

COMMUNICATION FUNCTION

Avarious kinds of communication are available for FW-9000NN as shown below SUPER INTELLIGENT TANK GAUGE:

1) STANDARD OUTPUT FORMAT OF FW-9000N

Transmission type	2 way-2 wire serial data transmission
Baud rate	2400 bps
Topology	Bus line wiring (16 tanks/BUS)
Distance	Max.5 km (Wiring condition: wiring resistance 20 Ω/ one way capacitance 0.5 μ F/m)

2) COMPATIBLE FORMATS FOR TOKYO KEISO'S EXISTING TANK DATE TRANSMITTERS

- a. DM-II type
- b. DB-M type
- c. DM type
- d. FW-7000 series

3) Other serial communications

- a. RS-485 MODBUS
 - Transmission type: RS-485 (2-wire)
 - Baud rate : 2400/4800/9600bps
 - Distance : 1.2km
- b. FOUNDATION Field bus
 - Base corrent : max 18mA
 - I/O signal : IEC 61158-2 compatible
 - Protocol : FOUNDATION Field bus H1
 - H1 Profile class : 31PS, 32L
 - H1 Device class : Link Master
 - Function block : 1-RB2, 1AI, 1TB
- c. TRL/2 compatible
 - *Field bus communication of Rosemount
- d. V1 compatible
 - *Field bus communication of E+H

EXAMPLE OF CONFIGURATION

1) Example of system configuration

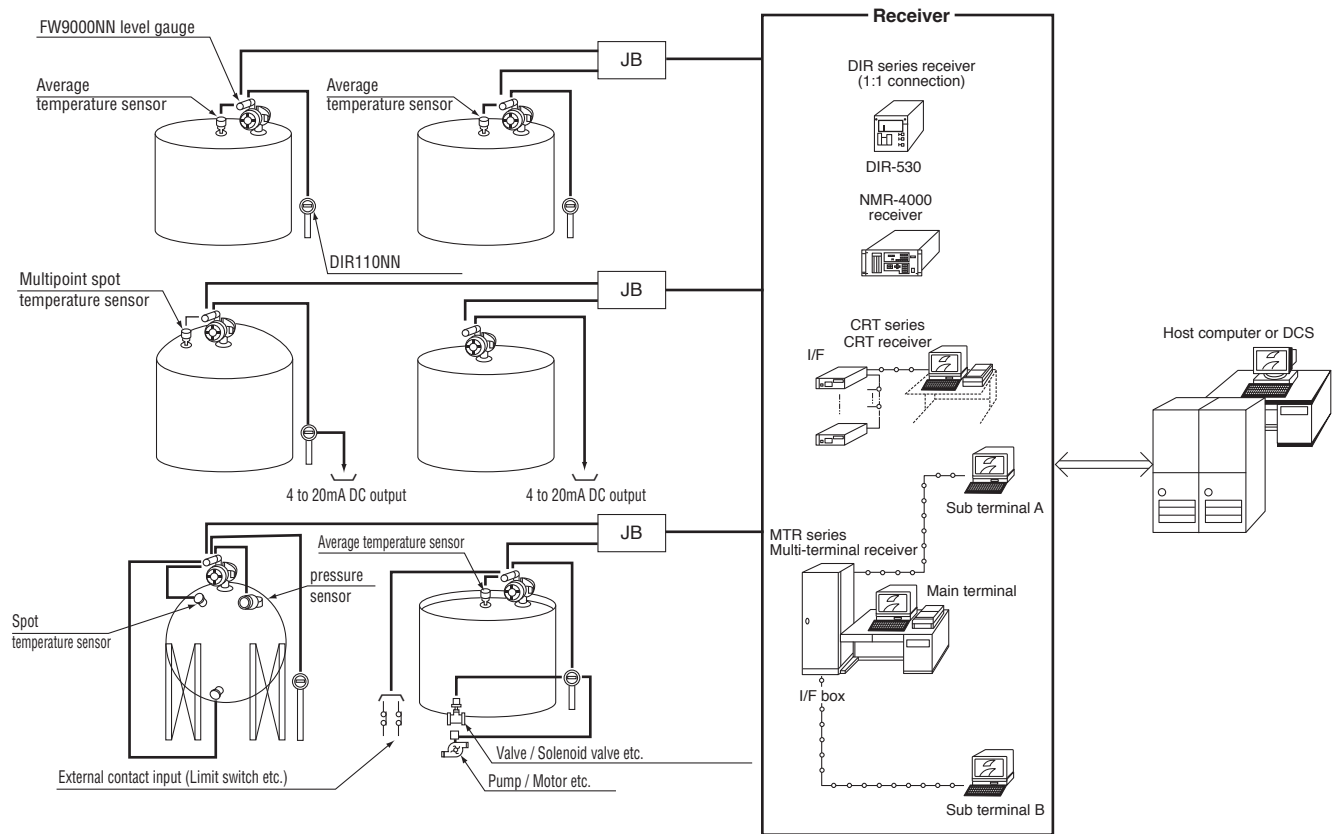

2) Example of Local configuration / wiring system figure

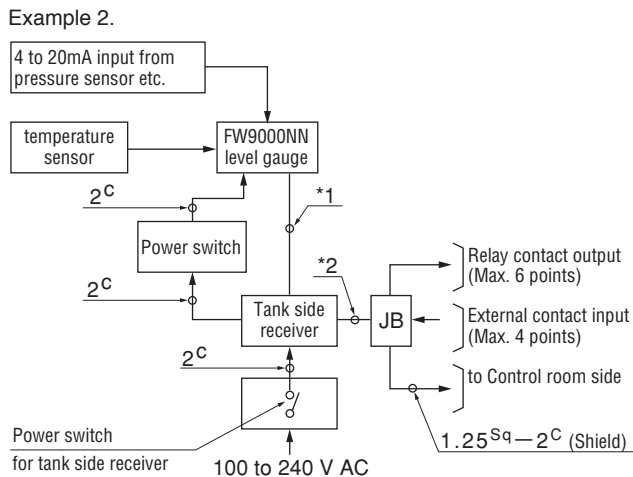
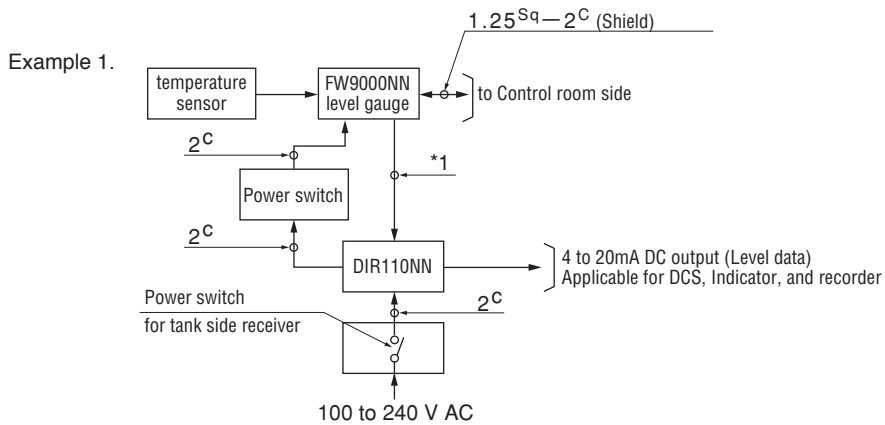

*1 : 1.25^{Sq}-n^C (Shield)
 n : Total of following
 For signal to control room 2^C
 For signal to tank side receiver 2^C

*2 : 1.25^{Sq}-m^C (Shield)
 m : Total of following
 For signal to control room 2^C
 For relay contact output (2+point)^C
 For external contact inputs (2+point)^C

ORDERING FORM

TANK SPECIFICATION	
LIQUID NAME	
DENSITY	
VISCOSITY	mPa·s
LIQUID TEMPERATURE	C
PRESSURE	MPa
TANK TYPE	<input type="checkbox"/> CONE ROOF <input type="checkbox"/> FLOATING ROOF <input type="checkbox"/> SPHERICAL <input type="checkbox"/> ()
MEASURING RANGE	mm
MAX. LEVEL CHANGE SPEED	mm/min.
MODEL CODE	FW9□□□NN□
PROCESS CONNECTION	
FLANGE SIZE	<input type="checkbox"/> 150mm (6") <input type="checkbox"/> 125mm (5") <input type="checkbox"/> 100mm (4") <input type="checkbox"/> 80mm (3") <input type="checkbox"/> Others ()
FLANGE RATING	<input type="checkbox"/> JIS 5K RF <input type="checkbox"/> JIS 10K RF <input type="checkbox"/> JPI #150 <input type="checkbox"/> ANSI#150 <input type="checkbox"/> JIS 20K RF <input type="checkbox"/> ANSI#300 <input type="checkbox"/> JIS30KRF <input type="checkbox"/> OTHERS ()
DISPLACER GUIDING	<input type="checkbox"/> NON-GUIDE <input type="checkbox"/> STAND PIPE <input type="checkbox"/> GUIDE WIRE <input type="checkbox"/> SPECIAL ()
MATERIAL	
DRUM COMPARTMENT	<input type="checkbox"/> AC2A <input type="checkbox"/> SCS13 <input type="checkbox"/> SCS14 <input type="checkbox"/> Others ()
DISPLACER	<input type="checkbox"/> SUS304 <input type="checkbox"/> SUS316 <input type="checkbox"/> SUS316L <input type="checkbox"/> MA (Equiv. to HASTELLOY) <input type="checkbox"/> PTFE <input type="checkbox"/> OTHERS ()
MEASURING WIRE	<input type="checkbox"/> SUS316 <input type="checkbox"/> MA (Equiv. to HASTELLOY) <input type="checkbox"/> FEP COVERED <input type="checkbox"/> OTHERS ()
OUTPUT AND INPUT	
A. REMOTE OUTPUT*	<input type="checkbox"/> WITHOUT DIGITAL OUTPUT <input type="checkbox"/> FF <input type="checkbox"/> FW-9000 (STANDARD) <input type="checkbox"/> DM-II <input type="checkbox"/> DM <input type="checkbox"/> DB-M <input type="checkbox"/> FW-7000 <input type="checkbox"/> RS-485 MODBUS <input type="checkbox"/> TRL/2 <input type="checkbox"/> V1
B. 4 to 20mA OUTPUT*	<input type="checkbox"/> NOT REQUIRED <input type="checkbox"/> REQUIRED (<input type="checkbox"/> LEVEL, <input type="checkbox"/> TEMPERATURE) <input type="checkbox"/> REQUIRED (HART) (<input type="checkbox"/> LEVEL, <input type="checkbox"/> TEMPERATURE)
C. CONNECTED THERMOMETER*	<input type="checkbox"/> NOT REQUIRED <input type="checkbox"/> SPOT TYPE <input type="checkbox"/> AVERAGE TYPE
EXTERNAL CONTACT OUTPUT	<input type="checkbox"/> NOT REQUIRED <input type="checkbox"/> REQUIRED (POINTS)
EXTERNAL ANALOG INPUT(4 to 20mA DC)	<input type="checkbox"/> NOT REQUIRED <input type="checkbox"/> REQUIRED
POWER SUPPLY	
VOLTAGE	V AC (100 to 240 V AC acceptable)
CABLE ENTRY	<input type="checkbox"/> G (=PF)FEMALE <input type="checkbox"/> NPT FEMALE <input type="checkbox"/> Others ()
CABLE GLAND	<input type="checkbox"/> CUSTOMER'S SCOPE <input type="checkbox"/> TOKYO KEISO SCOPE (Cable diameter mm)
SPECIAL MEASUREMENT FUNCTION	
INTERFACE MEASUREMENT	<input type="checkbox"/> NOT REQUIRED <input type="checkbox"/> REQUIRED (DENSITY : UPPER LOWER)
DENSITY MEASUREMENT	<input type="checkbox"/> NOT REQUIRED <input type="checkbox"/> REQUIRED
APPLICATION	<input type="checkbox"/> GENERAL <input type="checkbox"/> CUSTODY
CONSTRUCTION	<input type="checkbox"/> GENERAL <input type="checkbox"/> SANITARY FINISH <input type="checkbox"/> COLD REGION SPEC. <input type="checkbox"/> SPECIAL ()
ACCESSORIES	
CALIBRATION CHAMBER	<input type="checkbox"/> NOT REQUIRED <input type="checkbox"/> TOKYO KEISO SCOPE <input type="checkbox"/> CUSTOMER'S SCOPE
ISOLATION BALL VALVE	<input type="checkbox"/> NOT REQUIRED <input type="checkbox"/> TOKYO KEISO SCOPE <input type="checkbox"/> CUSTOMER'S SCOPE
LOCAL POWER SWITCH	<input type="checkbox"/> NOT REQUIRED <input type="checkbox"/> TOKYO KEISO SCOPE <input type="checkbox"/> CUSTOMER'S SCOPE

*: Up to two instruments are available.

* Specification is subject to change without notice.

TOKYO KEISO CO., LTD.

Head Office : Shiba Toho Building, 1-7-24 Shibakoen, Minato-ku, Tokyo 105-8558

Tel : +81-3-3431-1625 (KEY) ; Fax : +81-3-3433-4922

e-mail : overseas.sales@tokyokeiso.co.jp ; URL : http://www.tokyokeiso.co.jp