

BALL FLOAT TYPE

FB-7000

LEVEL SWITCH

GENERAL

FB-7000 is a ball float type level switch which is installed through tank nozzle or through external chamber. The incorporated micro switch is actuated when liquid level reaches set point. This microswitch contact can be utilized to drive buzzers, lamps or to control pumps and valves to monitor and control liquid level in vessels for safety and efficiency.

FEATURES

- Perfect isolation between tank side and electric compartment by magnetic coupling for safety.
- No moving part except float guarantees high durability.
- Easy installation and maintenance.
- External chambers are available for isolation from process.
- Flameproof enclosure: Usable at hydrogen atmosphere (Exd II CT6).

STANDARD SPECIFICATION

- Applicable fluid : Liquids (Density ≥ 0.35)*
Interface of two different liquids (Difference of Density ≥ 0.2)*
* : Min. 0.5g/cm^3 for repelling action type
Theoretically not suitable for liquids containing ferrous particles.
- Max.OP.Press : 4MPa (Subject to flange rating)
Up to 7MPa (at ambient temp.) available as special order.
Consult factory for further details.
- Liquid Temp : -170°C to $+400^\circ\text{C}$
*A cooling fin will be provided for low and high temp, versions. Refer to Model Code for details.
- Ambient temperature : -20 to $+80^\circ\text{C}$
 -10 to $+40^\circ\text{C}$ (Intrinsically safe)
 -20 to 55°C (Flameproof type)
- Process connection : 1) Tank nozzle installation standard 3" flange
3BJIS5KRF, 3BJIS10KRF, 3"JPI#150, 3"ANSI#150, 3BJIS20KRF, 3"JPI#300, 3"ANSI#300, Others (4" flange on request)

Production Possibility by Diameter

Diameter	Without Fin	With Fin	With Long Fin	Repelling type
3B (80A)	○	○	△	×
4B (100A)	○	○	○	○

○ : Possible to produce

△ : Production is possible when liquid density is more than 0.5g/cm^3 and inside diameter of nozzle is more than $\varnothing 73$.

× : No production can be made.

- 2) Through external chamber
Chamber connection to vessel :
1"SW, Rc1, 1BJIS10KRF, 1"JPI#150, 1"ANSI#150, 1BJIS20KRF, 1"JPI#300, 1"ANSI#300, Others

- Enclosure : 1) Weather proof (Equiv. to IP65)
2) Flameproof (Exd II CT6)
3) Intrinsically Safe (TIIS i3nG5)
Safety relay will be provided. In case such safety relay is in the scope of customer, specify water tight version.

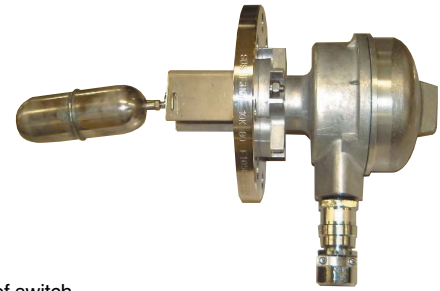

- Type of switch
Standard : SPDT microswitch
Opt. : SPDT \times 2 microswitch (Except for repelling action type)
- Contact capacity
Standard : AC250V, 5A (Resistance Load)
DC125V, 0.4A
Gold plated contact for Minute current available on request (DC30V, 0.1A) but to be less than 300°C
- Repeatability $\pm 5\text{mm}$
- Reset span : Max. 15mm (Fixed)
Max. 25mm (fixed) if with fin (except for repulsive type)

■ : Close
□ : Open

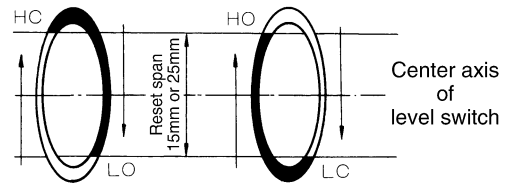

HC : Close for Increase HO : Open for Increase
LO : Open for decrease LC : Close for decrease
Put the center of reset span on the center of level switch.
(Normal temperature, atmospheric pressure, when making water test)

● Cable entry

Construction	Cable entry	Remarks
W, WP	G1/2	
EX	G1/2	Outside dia. of standard applicable cable: $\varnothing 10$ to 10.9
S, SP	G1/2	

(To be with adapter for other standards like NPT.)

Cable entry: Vertical and downward direction. Corresponding to 90° in horizontal direction. Specify when ordering.

- Cable termination : By M3.5 screw
- Material : Float : SUS316L
Float rod : SUS316 (SUS316L available on request)
Flange : SUS304 or SUS316 (SUS316L available on request)
Housing : Aluminum alloy
External chamber : Carbon steel, SUS304 or SUS316 (SUS316L available on request)
- High Pressure Gas Regulation certified version :
Level switches certified by Japanese High Pressure Gas Regulation are available and their manufacturing range is as follows. Consult factory for further details.

Material	Design Temp.	Design Press
Carbon steel	0 to $+350^\circ\text{C}$	7MPa
Stainless steel	-170 to $+350^\circ\text{C}$	(at ambient temp.)

(Connection size may be 4" and special form.)

MODEL CODE



1 Magnet action

0	Following Action (Standard)
1	Repelling Action Fig. 4

2 Connection flange

1	3BJIS5KRF
2	3BJIS10KRF
3	3BJPI#150
4	3"ANSI#150
5	3BJIS20KRF
6	3BJPI#300
7	3"ANSI#300
9	Others

Note: Refer to "Production Possibility by Diameter."

3 Enclosure

W	Weather proof
WP	Weather proof with JIS F15b gland*2
EX*4	Flame proof (EX d II CT6) with flame proof glands*3
S*1	Intrinsically Safe (i3nG5, Safety relay provided)
SP*1	Intrinsically Safe (i3nG5, Safety relay provided) with JIS F15b gland*2

*1 : If intrinsically safe relay is in the scope of customer, specify "W (Water tight)".

*2 : Inform us of the cable outside diameter.

*3 : Outside diameter of standard cable: ø10 to ø10.9.

If the cable outside diameter is except the above, inform us of the cable outside diameter. Outside diameter of cables available: Ø7 to Ø7.9 and Ø11 to Ø11.9.

*4 : For flame proof enclosure: Type; E, Ex-proof Class JIS d2 G4, and Gland: Nil. (Refer to Fig. 4.)

Inform us of the cable outside diameter if Ex-proof gland is required.

4 Material

3	Material Class 3
4	Material Class 4
9	Others

5 Contact Construction

S	SPDT (Single contact)
D	SPDT × 2 (Double contact)

6 Temperature Range T (°C) & Fin

0	-170 ≤ T ≤ -20	With long fin, Fig. 3
1	-20 < T ≤ +150	Without fin, Fig. 1-1, 1-2
2	+150 < T ≤ +200	With aluminum fin, Fig. 2
3	+200 < T ≤ +300	With long fin, Fig. 3
4	300 < T ≤ +400	With long fin, Fig. 3*

* : Special Switch and Internal mechanism for High temp. use provided.

7 Density ρ range (g/cm³)

1	0.8 < ρ ≤ 1.1
2	0.6 < ρ ≤ 0.8
3	0.5 < ρ ≤ 0.6
4	0.35 < ρ ≤ 0.5
5	1.1 < ρ
9	Interface detection*

* : Minimum 0.2 g/cm³ difference is required.

"Repelling type" is improper.

8 External chamber connection

0	No external chamber provided
1	1"SW
2	Rc1
3	1BJIS10KRF
4	1BJPI#150
5	1"ANSI#150
6	1BJIS20KRF
7	1BJPI#300
8	1"ANSI#300
9	Others

9 External chamber material

0	No external chamber provided
2	Carbon steel
5	SUS304
7	SUS316
9	Others

10 Gasket material (External chamber to level switch flange)

0	No external chamber provided (No gasket)	
3	PTFE	(V#7020 or equ.)
4	PTFE	(V#7030 or equ.)
5	METAL WOUND	(V#8591 SUS304 or equ.)
6	METAL WOUND	(V#8591 SUS316 or equ.)
9	Others	

11 Bolt, nut material (External chamber to level switch flange)

0	No external chamber provided	
1	SS400/SS400	
2	SNB7/S45C	
3	SUS304/SUS304	
9	Others	

DIMENSION AND MATERIAL

Level switch

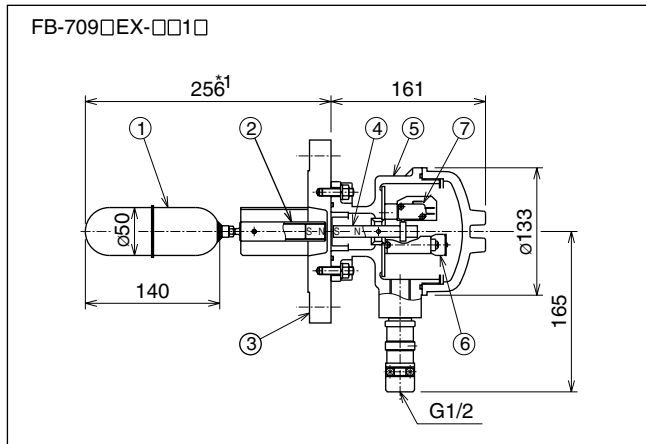

Fig. 1-1

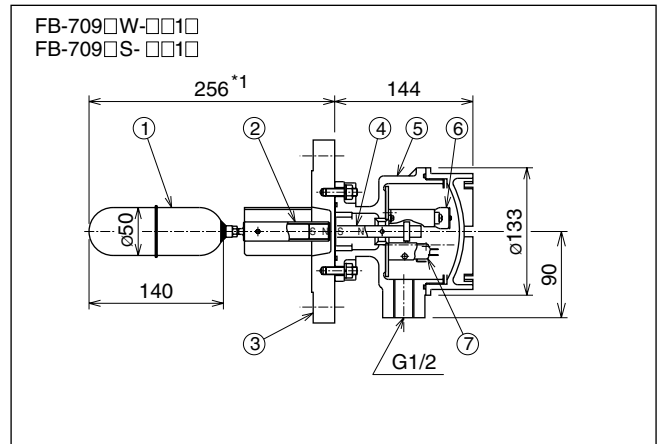

Fig. 1-2

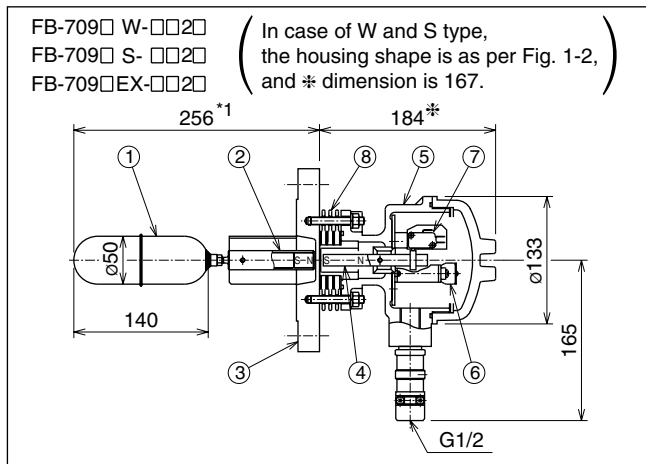

Fig. 2

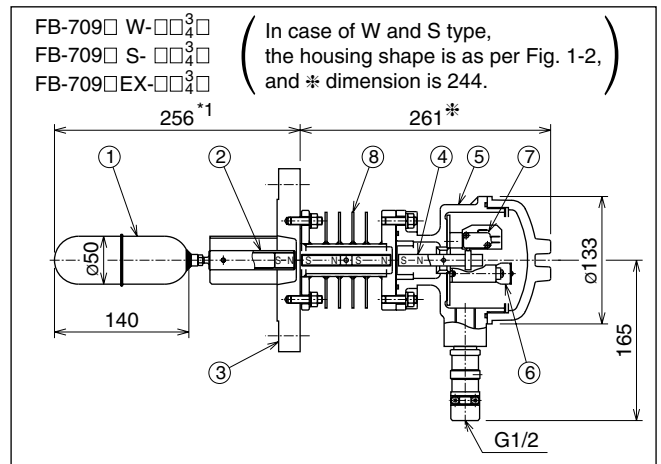

Fig. 3

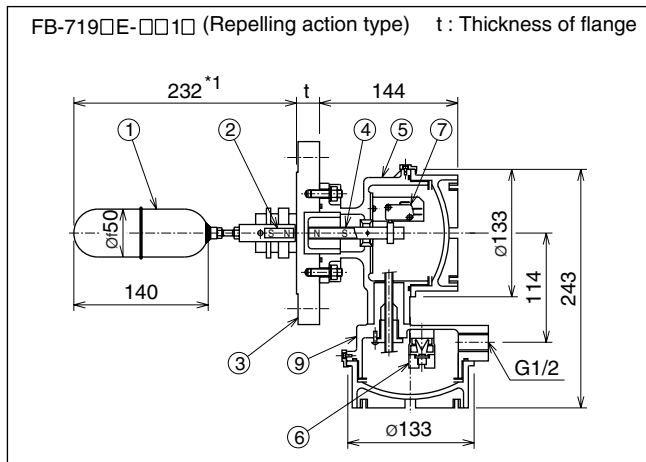

Fig. 4

<Material>

No.	Parts	Material Class 3	Material Class 4
1	Float	SUS316L	
2	Magnet	Assembly	
3	Flange	SUS304*2	SUS316*2
4	Magnet	Assembly	
5	Housing	Aluminum alloy	
6	Terminal	Assembly	
7	Microswitch	Assembly	
8	Cooling fin	Aluminum alloy (Fig. 2), SUS304 (Fig. 3)	
9	Terminal box	Aluminum alloy	

*1 : In case the Density is less than the following density of liquid, the dimension of float and from flange face to float end will become longer, and also the float shape will be changed.

- a) Following type: Less than 0.5 (g/cm³)
- b) Repelling type: Less than 0.6 (g/cm³)

External chamber

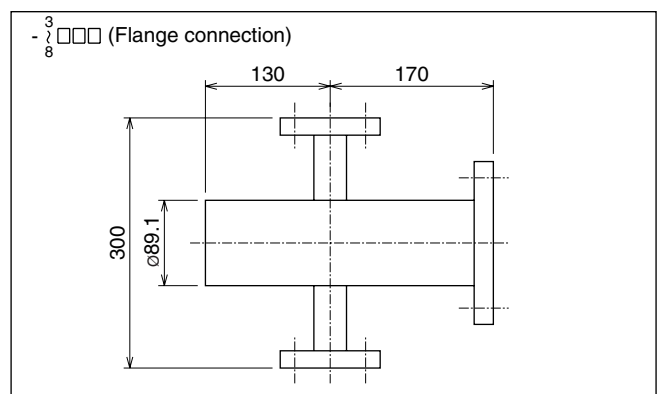
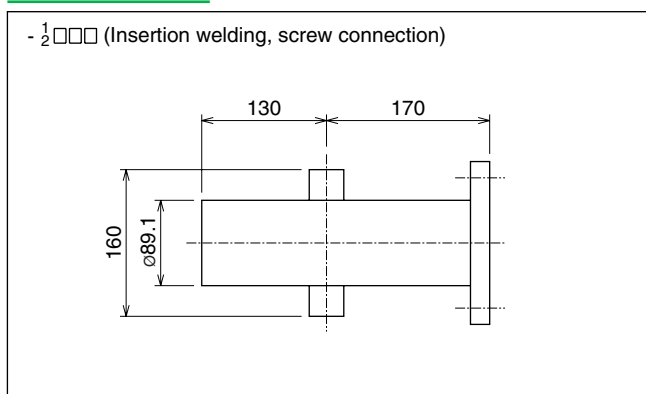

INTRINSICALLY SAFE RELAY

Safety relay is to be inserted into IS loop of FB-709□S or FB-709□SP version. Select suitable safety relay considering total number of contacts to be handled.

External dimensions

EB3C Dimensions

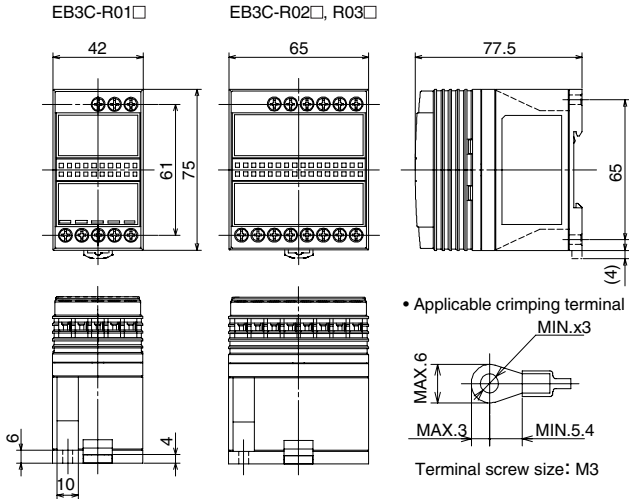

PRECAUTION FOR WIRING

- "S" Type (Intrinsically safe) and "EX" Type (Flameproof): Wiring work is to be carried out in accordance with a guide book issued by National Institute of Industrial Safety.
- Flameproof version has been approved, assembled with the flameproof equipment. Be sure to use the cable gland of designation of our company.

SUGGESTIONS

- 1) Bolts, Nuts and gasket for process connection are in the customers' scope of supply.
- 2) Minimum 73mm inner diameter is required for tank side nozzle. The level switch is to be installed so that the center axis of the level switch is on that of nozzle pipe.
- 3) In case there is flow in liquid by a stirring machine, there may be malfunction and damage. Install an inner chamber.
- 4) It is not suitable to use under such operating conditions as the liquid freezes, congeals or sticks.

ORDERING INFORMATION

Specify Model Code.

In case "9:others" is/are in the model code, indicate the details separately.

* Specification is subject to change without notice.

TIV TOKYO KEISO CO., LTD.

Head Office : Shiba Toho Building, 1-7-24 Shibakoen, Minato-ku, Tokyo 105-8558
 Tel : +81-3-3431-1625 (KEY) ; Fax : +81-3-3433-4922
 e-mail : overseas.sales@tokyokeiso.co.jp ; URL : <http://www.tokyokeiso.co.jp>

