



TECHNICAL GUIDANCE

For assembling onto devices, test plants and general industrial processes

M-900 Series MICRO FLOWMETER

OUTLINE

M-900 series MICRO FLOWMETER is a metal tube variable area flowmeter for small flow measurement. All metallic construction covers even high temperature and high pressure applications.

Thanks to compact design, M-900 is suitable for assembling onto various devices. It also covers small sized industrial processes.

M-900 series MICRO FLOWMETER has been used for nuclear power plants for long time and HPGSL certified version is also available.

In addition to local indication, various versions including pneumatic, electric and alarm output types are ready to meet your requirements of remote monitoring and control.

FEATURES

1. Compact design
Small and light design offers easy installation onto panels as well as process pipings.
2. High sensitivity
The pivot bearing and light weight pointer enable to follow float movement swiftly.
3. Suitable for corrosive and opaque fluids
Anti-corrosive materials such as titanium and MA276 are available to meet your specifications.
4. Easy reading of scale and pointer
The long pointer and wide linearized scale plate make your reading easier with up-and-down movement of pointer corresponding flow rate.
5. Supporting devices
Various supporting devices to meet your requirements are available such as flow control needle valve, strainer and constant flow valve.



OPERATING PRINCIPLE

The flow path has a tapered part. A float in which a magnet is moulded is located in the tapered tube. The fluid is introduced from the bottom end of flowmeter and goes through the tube upward.

Because of the differential pressure produced by the float and tapered tube, the float is pushed upward and stops at a position where the weight of float and the differential pressure balance. Thus, the position of float corresponds to the flow rate. The moulded magnet in the float attracts the pointer, and the pointer indicates the flow rate on the scale plate.

The inside of the tube and indication mechanism are totally isolated by magnetic coupling.

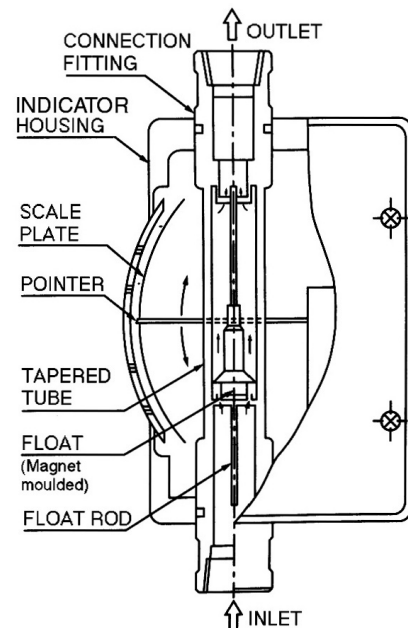

MODEL CODE

MODEL CODE						Contents
	M-9			-	-	
Construction	EP-					Dust-proof and weatherproof
	IS-					Flameproof *1
						Intrinsically safe *2
Function		0				Local indication
		1				Pneumatic transmission
		2				Electric transmission
		5				Alarm output with reed switch
		6				Alarm output with photo electric switch
	Flow direction		1			
		2				Bottom→Top side
		3				Bottom side→Top side
		4				Bottom side→Top
		5				Bottom rear→Top rear (only available for local indicator type)
Additional function 1			-	D		With liquid damper *3
			-	DU		With gas damper
Additional function 2			-	VU		Upstream needle valve
			-	VL		Downstream needle valve
Special						/Z

*1 Flameproof type is applied only for electric transmission type EP-M-92□.

*2 Intrinsically safe type is applied only for alarm output type IS-M-95□.

*3 Liquid damper can be provided on the flowmeters with Bottom side→□ and Bottom rear→Top rear connections only.

ADDITIONAL FUNCTION

1. Liquid damper Model M-9□□-D

A damper mechanism is required for gas and steam measurement especially at low pressure service to prevent float hunting.

The damper installed at the bottom of flowmeter ensures the accuracy and durability of flowmeter.

The damping mechanism works to reduce the abrupt movement of float utilizing the resistance generated between oil in the damper and damping element connected to float rod.

The damper is recommended also for the liquid service having a pulsation flow.

2. Gas damper Model M-9□□-DU

The gas damper which requires no damper liquid is available for gas measurement. A mechanical damper consists of a cylinder and a piston connected with float rod. This type needs no space for damping mechanism at the bottom of flowmeter. Therefore, this damper is applied for any direction type of flowmeters which result in the flexibility of piping design. Furthermore unnecessary re-filling of damper liquid improves the maintainability.

The gas damper is effective for the low pressure gas services which cause hunting of indication and for the services which does not permit damping liquids. It is highly recommended to have gas damper for the services less than 0.3MPa pressure and without needle valve at the downstream.

However, this type is applicable only for dry gas services and not applicable for liquids nor condensable vapors. Neither chlorine gas which is synthesized easily with other chemicals nor gases containing foreign materials like rust, dust and oil

is applicable because of the ingress into the piston and cylinder which might lead to the malfunctioning of the flowmeter.

3. Needle valve M-9□□-V

A needle valve used for flow rate control is recommended at the downstream of flowmeter to avoid hunting for gas measurement.

On the other hand, for liquid measurement the pulsation may be eased by the valve located upstream.

4. Magnet strainer. See clause "Accessories" at the following page.

The iron particles contained in liquids may cause the malfunctioning of flowmeter due to the attracted irons on the moulded magnet in the float. The particles can be eliminated with the magnet strainer at the inlet of the flowmeter. For this purpose dedicated strainer with 100 mesh (optionally 200 mesh) is available.

5. Purge set. See clause "Accessories" at the following page.

A set of M-900 micro flowmeter and constant flow valve keeps constant flow rate even supply pressure or down stream pressure is fluctuated.

ACCESSORIES

NEEDLE VALVES

Needle valve for flow control. It will be assembled onto flowmeter

● STANDARD SPECIFICATION

- Nominal size Rc3/8
- Max. Op. Pressure Less than 3 MPa
- Fluid temperature -30 to +150°C
- Material SUS316

High pressure versions are available on request.
Consult factory for details

MAGNET STRAINER

A magnet strainer will be assembled into the flowmeter before delivery on request.

● STANDARD SPECIFICATION

- Nominal size 1/4", 3/8", 1/2"
- Max. Op. Pressure 1.5MPa
- Max. Op. temperature 200°C
- Filter Std. 100 mesh as standard, 200 mesh as option.
- Material SUS304, SUS316

PURGE SET

Separate TECHNICAL GUIDANCE of "C" Series is available on request for this version.

● External dimension of M-901-V (With valve)

Standard type

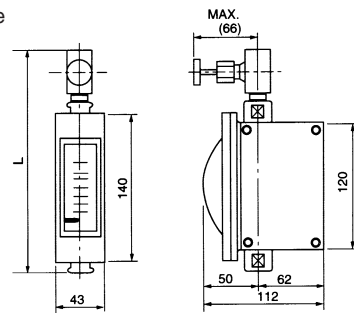

Thread size	Rc1/4	Rc3/8	Rc1/2
L (mm)	245	225	275

* Screw socket (s) provided for Rc1/4 and Rc 1/2.
* "L" length of the flowmeter with gas damper is extended by 40mm at downstream.

● External dimension of MAGNET STRAINER

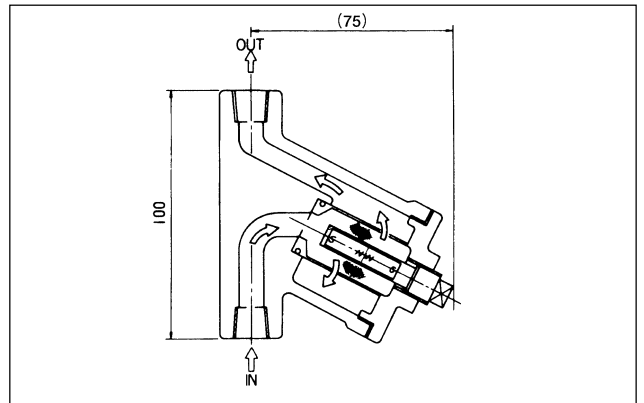

● CM-21-900 TYPE PURGE SET



Local Indication version

STANDARD VERSION

OUTLINE

Model M-900 is a local indicator for very small flow measurement. It indicates flow rate of liquids and gases with a scale and a pointer. Its purely mechanical construction requires neither electric power nor air.

STANDARD SPECIFICATION

Measuring object Liquids and Gases
 The model with damper, M-90□-D or M-90□-DU only applied for standard type is recommended for low pressure gas services of less than 0.3MPa.

Measuring range

Type	Liquids *1 L/h	Gases *2 L/h(nor)
Standard type	Min. 0 to 2 Max. 0 to 300	Min. 0 to 60 Max. 0 to 8500
Large flow type	Min. 0 to 300 Max. 0 to 600	Min. 0 to 8500 Max. 0 to 17000

*1: Water (density 1.0g/cm³, viscosity 1.0 mPa·s) *2: Air at 0°C, 1atm

Viscosity limit for liquid flow measurement

Full scale	Viscosity limit (mPa·s)
up to 20L/h	5
20 to 50L/h	10
More than 50L/h	20

Press. Range

Std. up to 10MPa
 Opt. up to 20MPa
 (Subject to flange rating for flange connection version)

Temp. Range

Std. 0 to 149°C
 Consult Tokyo Keiso for the service 150°C or more.
 Low temperature version -20°C to -1°C
 High temperature version 150°C to 200°C
 M-90□-D and M-90□-DU 0°C to 149°C
 Consult Tokyo Keiso for the service 150°C or more.

Indication accuracy

±3% F.S. However, high accurate type has ±2% F.S.
 ±5% F.S. for the measurement less than 10L/h or 300 L/h (nor) for gas measurement. However, high accurate type has ±3% F.S.

Rangeability

10 : 1
 10:2 for the measurement less than 5L/h or 150 L/h (nor) for gas measurement. However, 10:1 is available on request.

Process connection

Type	Std.	On request
Standard type	Rc 3/8	Rc 1/4, 1/2 10, 15, 20, 25mm flange
Large flow type	Rc 1/2	Rc 3/8, 3/4 15, 20, 25mm flange

Material availability

Part name	Std.	Available material
Body	SUS304	SUS316, (SCS14) SUS316L, MA276*, Titanium*
Tapered tube	SUS304	SUS316, SUS316L, MA276*, Titanium*
Float	SUS304	SUS316, SUS316L, MA276*, Titanium*

* Not applied for flowmeter with gas damper type.



Paint Munsell 7.5BG4/1.5 (Indicator housing)
 AMB. Temp. -30 to 80°C
 Enclosure of indication part Dust-proof and weatherproof (Equivalent to IP54)

DIMENSIONS

● STANDARD, SCREW CONNECTION M-901

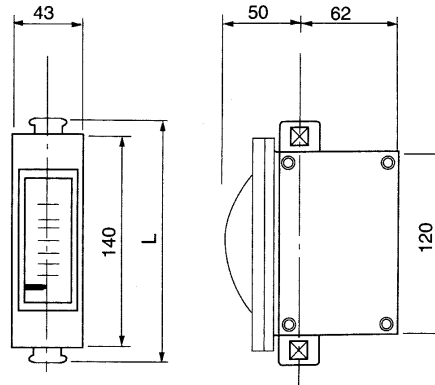

Thread size	1/4	3/8	1/2
L (mm)	180	160	190

* Screw socket (s) provided for Rc 1/4 and Rc 1/2.

* "L" length of the flowmeter with gas damper is extended by 40mm at downstream.

● STANDARD, SCREW CONNECTION M-901

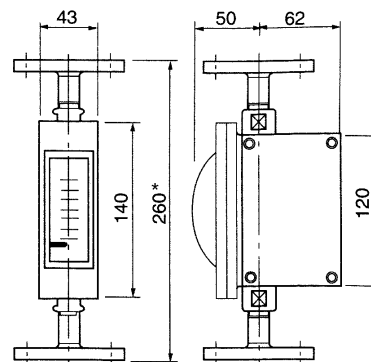

* Length of flowmeter with gas damper is extended by 40mm at downstream.

● HIGH/LOW TEMP. VERSION, SCREW CONNECTION M-901

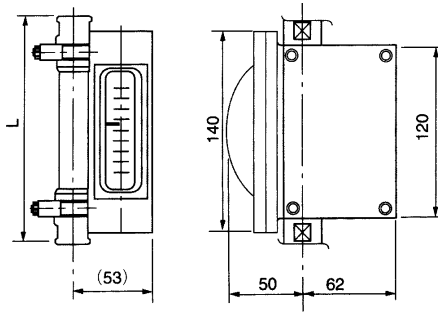

Thread size	1/4	3/8	1/2
L (mm)	180	160	190

* Screw socket (s) provided for Rc 1/4 and Rc 1/2.

* "L" length of the flowmeter with gas damper is extended by 40mm at downstream. The gas damper is not applied for high temperature version.

● LARGE FLOW VERSION, SCREW CONNECTION M-901

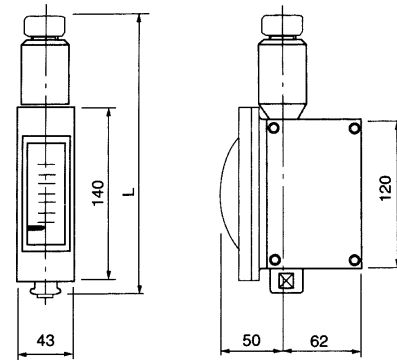

Thread size	3/8	1/2	3/4
L (mm)	230	265	245

* The gas damper is not applied for this version. AM type is recommended.

● HIGH/LOW TEMP. VERSION, FLANGE CONNECTION M-901

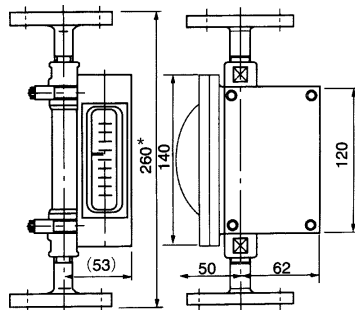

* "L" length of the flowmeter with gas damper is extended by 40mm at downstream. The gas damper is not applied for high temperature version.

● LARGE FLOW VERSION, FLANGE CONNECTION M-901

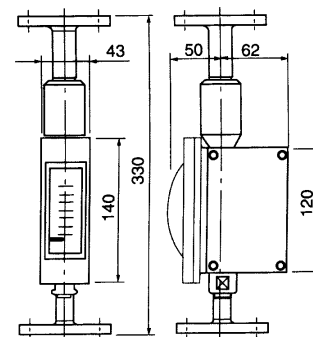

* The gas damper is not applied for this version. AM type is recommended.

FOR GAS SERVICES WITH LIQUID DAMPER

OUTLINE

M-90□-D equipped with liquid damper is exclusively used for low pressure gas services.

The other specifications are same as the M-900 series used for general purposes.

High and low temperature types are not available.

STANDARD SPECIFICATION

Measuring range

Type	Gases *L/h (nor)
Standard type	Min. 0 to 60 Max. 0 to 8500
Large flow type	Min. 0 to 8500 Max. 0 to 17000

*: Air, 0°C, 1atm

Press. Range Max. 3MPa subject to flange rating for flange connection type.

DIMENSIONS

M-904-D

STANDARD, FLANGE CONNECTION LARGE FLOW, FLANGE CONNECTION

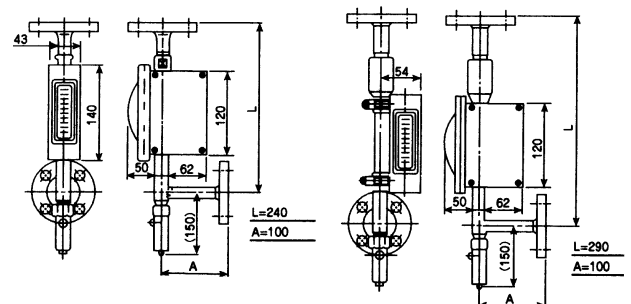

Thread size		1/4	3/8	1/2
Standard type	L	210	190	215
	A	40	45	45
Large flow type	L	260	260	270
	A	40	45	45

Pneumatic output version

OUTLINE

M-910 is a metal tube micro flowmeter with pneumatic transmitter. In addition to local flow indication by scale plate and pointer, pneumatic output of 20 to 100kPa is obtained. Air supply and output pressure gauges are provided for checking of operating condition. Air-set (Filter regulator) is optionally integrated.

STANDARD SPECIFICATION

Measuring object Liquids and Gases
 The model with damper, M-91□-D or M-91□-DU is recommended for low pressure gas services of less than 0.3MPa.

Measuring range

Type	Liquids *1 L/h	Gases *2 L/h (nor)
Standard type	Min. 0 to 2 Max. 0 to 300	Min. 0 to 60 Max. 0 to 8500

*1: Water (density 1.0g/cm³, viscosity 1.0 mPa.s) *2: Air at 0°C, 1atm

Temp. Range 0 to 80°C
 Indication Accuracy ±5% F.S.
 Enclosure of indication part
 Dust-proof and weatherproof (Equivalent to IP54)

SPECIFICATION OF PNEUMATIC TRANSMITTER

Output 20 to 100kPa against 0 to 100% span
 (0.2 to 1.0 barG available on request)
 Air supply 0.14 (±0.01)MPa
 Air consumption Approx. 14L/min. (nor)
 AMB. Temp -30 to 60°C
 Conduit Rc1/4 threads
 Pressure gauge 0 to 0.2MPa range pressure gauges are provided both for air supply and outlet

The other specifications are same as the M-900 series used for general purposes.
 High and low temperature types, and large flow type are not available.



DIMENSIONS

● STANDARD, SCREW CONNECTION M-911

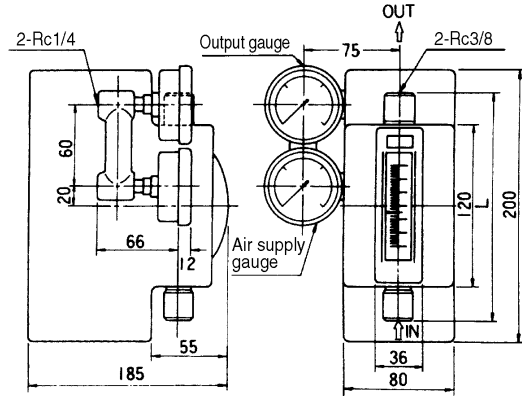

Thread size	1/4	3/8	1/2
L (mm)	180	160	190

* Screw socket (s) provided for Rc 1/4 and Rc 1/2.
 * "L" length of the flowmeter with gas damper is extended by 40mm at downstream.

● AIR SET INTEGRATED, FLANGE CONNECTION M-911

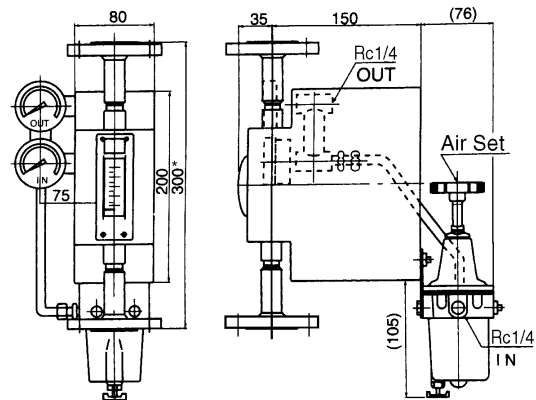

* Length of flowmeter with gas damper is extended by 40mm at downstream.

Electric output version

OUTLINE

M-920 is a metal tube micro flowmeter with electric output. In addition to local flow indication by scale plate and pointer, electric output of DC4 to 20mA is obtained for remote indication. In addition to dust-proof and weatherproof constructions, the flameproof version is ready to cover even the hazardous applications likely at chemical plants.

STANDARD SPECIFICATION

Measuring object Liquids and Gases
 The model with damper, M-92□-D or M-92□-DU only applied for standard type is recommended for low pressure gas services of less than 0.3MPa.
 Large flow type with damper and flameproof type with gas damper is not available.

Measuring range

- Dust and watertight equivalent to IP54

Type	Liquids *1 L/h	Gases *2 L/h (nor)
Standard type	Min. 0 to 10 Max. 0 to 300	Min. 0 to 280 Max. 0 to 8500
Large flow type	Min. 0 to 300 Max. 0 to 600	Min. 0 to 8500 Max. 0 to 17000

- Flameproof type with enclosure equivalent to IP65

Type	Liquids *1 L/h	Gases *2 L/h (nor)
Standard type	Min. 0 to 30 Max. 0 to 100	Min. 0 to 900 Max. 0 to 2800
Large flow type	NOT AVAILABLE	NOT AVAILABLE

*1: Water (density 1.0g/cm³, viscosity 1.0 mPa-s) *2: Air at 0°C, 1atm

Temp. Range 0 to 60°C
Indication Accuracy ±5% F.S. However, high accurate type has ±3% F.S.

SPECIFICATION OF ELECTRIC TRANSMITTER

Power supply DC24V ±10%
Output signal DC4 to 20mA against 0 to 100% span
Accuracy of transmitter ±1% F.S.
Max. load Max. 400Ω
AMB. Temp. 0 to 50°C
Insulation resistance DC500V, 20MΩ or more
Withstand voltage AC1000V (1min.)
Cable entry G1/2 thread
Construction Dust-proof, weatherproof, or flameproof *
 *d2G4 Approval number 24685

The other specifications are same as the M-900 series used for general purposes.
 High and low temperature types are not available.

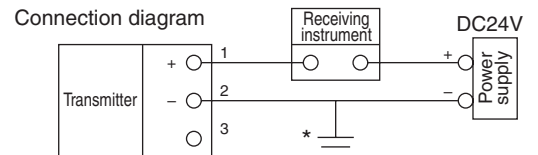

* Ground power supply line at minus polarity.

DIMENSION

- Dust-proof and weatherproof, FLANGE CONNECTION, M-921(STANDARD)

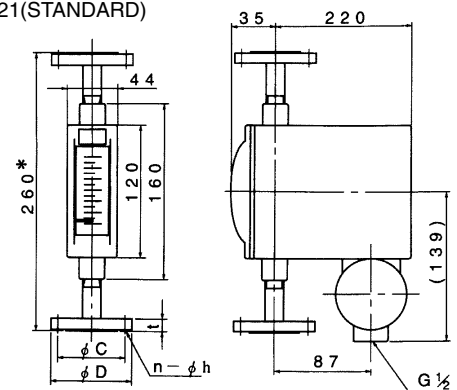

* 300mm for 1" flange conn.

* Length of flowmeter with gas damper is extended by 40mm at downstream.

- FLAMEPROOF, FLANGE CONNECTION, EP-M-921

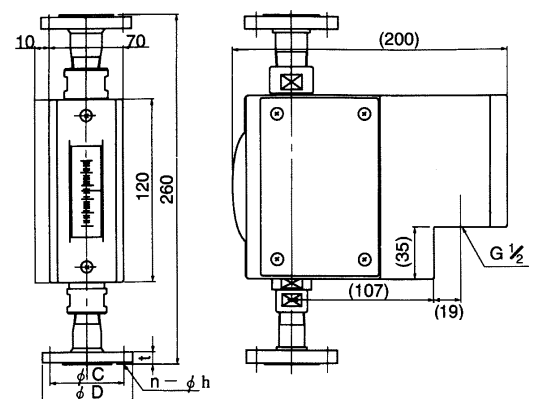

Alarm output with reed switch

OUTLINE

M-950 is a metal tube micro flowmeter with reed switch alarm contact. In addition to local flow indication by scale plate and pointer, alarm contact output at set point is obtained.

STANDARD SPECIFICATION

Measuring object Liquids and Gases
 The model with damper, M-95□-D or M-95□-DU only applied for standard type is recommended for low pressure gas services of less than 0.3MPa.
 Large flow type with damper is not available.

Measuring range

Type	Liquids *1 L/h	Gases *2 L/h (nor)
Standard type	Min. 0 to 2 Max.0 to 300	Min. 0 to 60 Max.0 to 8500
Large flow type	Min. 0 to 300 Max.0 to 600	Min. 0 to 8500 Max.0 to 17000

*1: Water (density 1.0g/cm³, viscosity 1.0 mPa·s) *2: Air at 0°C, 1atm

Temp. Range 0 to 80°C
 Enclosure of indication part
 Dust-proof and weatherproof (Equivalent to IP54)

SPECIFICATION OF ALARM CONTACT

Type of contact 1 contact by reed switch
 Either "a" or "b" instantaneous contact.
 Provide holding circuit if required.
 Reset span Max. 30% F.S.
 Alarm setting Adjustable within the measuring range with external setting knob
 Contact capacity AC10VA (Resistance load), DC10W
 Max. current 0.25 A
 Max. voltage DC100V, AC125V
 Insulation resistance 100MΩ or more (at DC500V)
 Withstand voltage between contacts
 DC250V
 Cable entry G1/2 thread
 Safety barrier Type EB3C-R manufactured by IDEC will be supplied on your request.

The other specifications are same as the M-900 series used for general purposes.
 High and low temperature types are not available.



Connection diagram

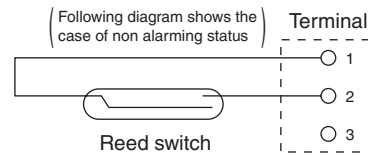

DIMENSIONS (M-951 TYPE)

● STANDARD, SCREW CONNECTION M-951

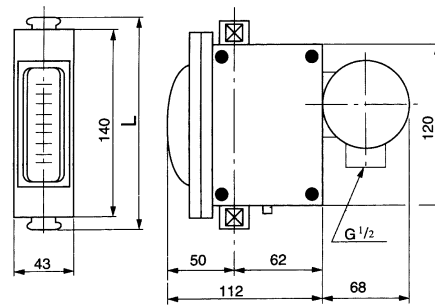

Thread size	1/4	3/8	1/2
L (mm)	180	160	190

* Screw socket (s) provided for Rc 1/4 and Rc 1/2.
 * "L" length of the flowmeter with gas damper is extended by 40mm at downstream.

● STANDARD, FLANGE CONNECTION M-951

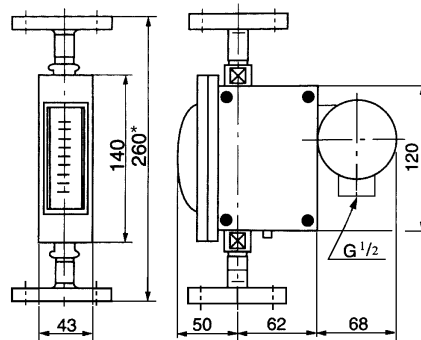

* Length of flowmeter with gas damper is extended by 40mm at downstream.

Alarm output with photo electric switch

OUTLINE

M-96□ is a metal tube micro flowmeter with photo electric switch. In addition to local flow indication by scale and pointer, 2 alarm contacts are equipped and their alarm points are set with the external knob.

STANDARD SPECIFICATION

Measuring object Liquids and Gases
 The model with damper, M-96□-D or M-96□-DU only applied for standard type is recommended for low pressure gas services of less than 0.3MPa.

Type	Liquids *1 L/h	Gases *2 L/h (nor)
Standard type	Min. 0 to 2 Max.0 to 300	Min. 0 to 60 Max.0 to 8500
Large flow type	Min. 0 to 300 Max.0 to 600	Min. 0 to 8500 Max.0 to 17000

*1: Water (density 1.0g/cm³, viscosity 1.0 mPa·s)
 *2: Air at 0°C, 1atm

The other specifications are same as the M-900 series used for general purposes.

High and low temperature types are not available.

SPECIFICATION OF ALARM CONTACT

Alarm function 2 alarms
 Contacts 1C×2 points relay contact
 Reset span Max. 2% F.S.
 Alarm setting Adjustable within the measuring range with external setting knob
 Contact capacity AC1200VA, DC240W (Resistance load)
 Max. current 10A
 Max. voltage DC100V, AC125V
 Power supply AC100V±10% 50/60Hz
 Power consumption 5VA
 Insulation resistance 100MW or more at DC500V
 Withstand voltage AC1500V 1minute
 Ambient temp. 0 to 60°C
 Enclosure Dust-proof and weatherproof

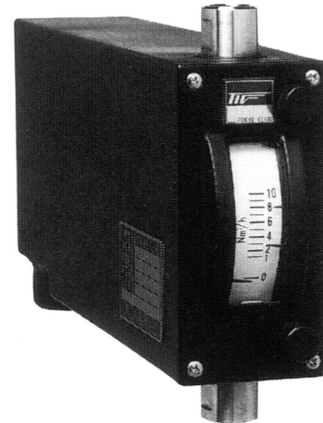

Connection diagram

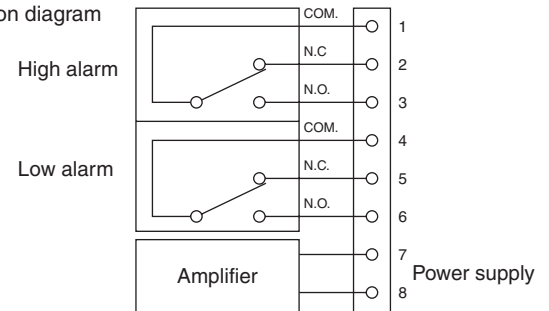

DIMENSIONS

● STANDARD, SCREW CONNECTION M-961

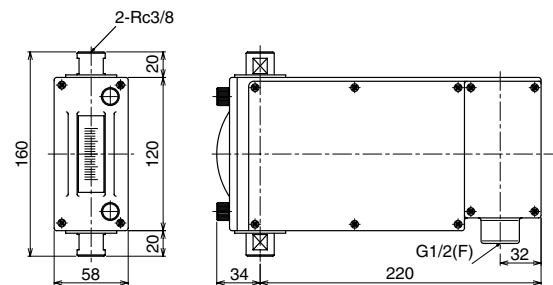

Connection screw size	1/4	3/8	1/2
L (mm)	180	160	190

* Screw socket(s) provided for Rc1/4 and Rc1/2.

* Length of flowmeter with gas damper is extended by 40mm at downstream.

● STANDARD, FLANGE CONNECTION M-961

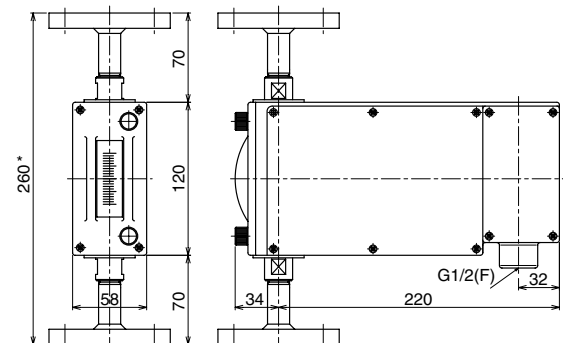

* Length of flowmeter with gas damper is extended by 40mm at downstream.

* Specification is subject to change without notice.

TIV TOKYO KEISO CO., LTD.

Head Office : Shiba Toho Building, 1-7-24 Shibakoen, Minato-ku, Tokyo 105-8558

Tel : +81-3-3431-1625 (KEY) ; Fax : +81-3-3433-4922

e-mail : overseas.sales@tokyokeiso.co.jp ; URL : http://www.tokyokeiso.co.jp



ISO 9001 Certified
 JQA-2172