



TECHNICAL GUIDANCE

METAL TUBE VARIABLE AREA FLOWMETER

AM9100 Series

■ GENERAL

The AM9100 series metal tube variable area flowmeters have the unified face-to-face dimension 250mm.

Having developed the current well-accepted AM7000 series, the AM9100 has a compact and unified construction which makes piping design simpler and saves installation space, leading to a low engineering cost.

In addition to highly reliable mechanical local indicator, a variety of standard-equipped functions such as electric transmission, local flow integration and integrated flow transmission by pulse, alarm, and digital communication of these data can meet your various requirements. The AM9100 covers liquid, gas and steam measurement in various fields.

■ FEATURES

● FULL LINE-UP TO MEET ALL POSSIBLE REQUIREMENTS !!

All the necessary functions required for variable area flowmeter, i.e. local indication, electric transmitters, local flow integration, PROFIBUS PA & HART communication, integrator with scaled pulse output and alarm are now available from one line.

● COMPACT DESIGN

Smaller and lighter... To suit modern needs.

Unified face-to-face dimension 250 mm makes piping design easier.

● WIDE PRESSURE RANGE

150 lbs and 300 lbs rating are available as standard and higher pressure versions are also available as option.

● HART COMMUNICATION PROTOCOL AND PROFIBUS PA

● CORRESPONDING TO EXPLOSION PROOF CONSTRUCTION

Certification: TIIS, KOSHA, NEPSI, ATEX & IECEx

● DUST TIGHT AND WATER IMMERSION PROOF

IP67



MODEL CODE

Basic model		Material/Connection code				Function 1 code	Function 2 code etc.	Basic model and Function 1 Code may be indicated in the quotation.		
AM9	□ □ □ □	-	□ □ □ □ □ □ □ □	-	□ □ □ □ □ □ □ □	/	□ □ □ □ □ □ □ □	Specifications		
Flow direction	1							Bottom→Top		
Function of indicator	L							Local indication		
	E							Electric transmitter		
	H							Electric transmitter with HART communication		
	P							PROFIBUS PA Communication		
	T							Local integration		
	R							Reed switch		
	N							Proximity switch		
Explosionproof	M							Microswitch		
	W							Dust tight, water immersion proof, non-explosionproof		
	E							Flameproof version	Except for alarm output	
Wetted material	S							Intrinsic safety version	Except for integrator with scaled pulse output	
		- 0 2						Material of main body : 304SS/SCS16	Material of float : 316LSS	
Rating		- 0 4						316LSS/SCS16	316LSS	
	J 1							JIS 10K		
	J 4							JIS 20K		
	A 2							ANSI CLASS 150		
	A 5							ANSI CLASS 300		
	P 2							JPI CLASS 150		
	P 5							JPI CLASS 300		
Z Z							Others			
Connection			R					R.F.		
Connection size				- 1				15 mm (1/2")		
				- 2				20 mm (3/4")		
				- 3				25 mm (1")		
				- 4				40 mm (1-1/2")		
				- 5				50 mm (2")		
				- 6				65 mm (2-1/2")		
				- 8				80 mm (3")		
				- A				100 mm (4")		
				- B				125 mm (5")		
				- C				150 mm (6")		
				- D				200 mm (8")		
			- Z				Others			
Additional function 1	Additional function					/ D U		Gas damper		
Additional function 2	Output function					/ E 1		Electric transmitter		
						/ E 2		Electric transmitter (intrinsically safe)		
						/ H 1		Electric transmitter with HART communication		
						/ H 2		Electric transmitter with HART communication (intrinsically safe)		
						/ P 1		PROFIBUS PA communication		
						/ P 2		PROFIBUS PA Communication (intrinsically safe)		
						/ T 1		Local iintegrator+Electric transmitter+integrator with scaled pulse (or alarm)		
	Explosionproof type					/ T H		Local indication+Analog current output with HARTcommunication+Integrated pulse (or alarm)		
						/ R	<input type="checkbox"/>	Reed switch	<input type="checkbox"/> shows conditions of switch action.	
						/ N	<input type="checkbox"/>	Proximity switch	A: High alarm CLOSE(ON), B: High alarm OPEN(OFF), C: Low alarm CLOSE(ON), D: Low alarm OPEN(OFF) Ex. Reed switch/2-point alarm (High alarm CLOSE X 1, OPEN X 1): /RAB	
						/ M	<input type="checkbox"/>	Microswitch		
						/ J E		TIIS Flameproof version	Except for alarm output (See page 12 for details.)	
					/ K E		KOSHA Flameproof version			
					/ C E		NEPSI Flameproof version			
	Cable entry					/ E E		ATEX Flameproof version		
				/ E E		IECEx Flameproof version (Specify separately.)				
				/ J I		TIIS Intrinsical safety version	Except for integrator with scaled pulse output (See page 12 for details.)			
				/ K I		KOSHA Intrinsical safety version				
				/ C I		NEPSI Intrinsical safety version				
				/ E I		ATEX Intrinsical safety version				
Option	Cleaning					/ M 2		M20×1.5(F)	Except for integrator with scaled pulse output	
						/ G 1		G1/2(F)	Except for integrator with scaled pulse output	
	Painting Test					/ G 2		G3/4(F)	Only integrator with scaled pulse output	
						/ N 1		NPT1/2(F)	Except for integrator with scaled pulse output	
Accessory					/ N 2		NPT3/4(F)	Only integrator with scaled pulse output		
					/ O L		Oil-free treatment			
					/ W L		Water-free treatment			
Special spec.	Double scale					/ A P		Pickling treatment		
						/ P S		Special painting color		
	Others					/ L T		Airtight test		
						/ P C		Waterproof connector	Except for flameproof version	
				/ F G		Flameproof cable gland				
				/ A C		Other accessories				
				/ W S		Double scale, output for main scale	Except for alarm output			
				/ W E		Double scale, output for main and sub scales	Except for Alarm output and local integration			
				/ Z Z		Contact us for details.				

STANDARD SPECIFICATION

FUNCTIONS

AM91□□	AM91□□/E□	AM91□□/H□	AM91□□/P□	AM91□□/T□	AM91□□ /R□, /N□, /M□
Local indication	Local indication Electric transmitter	Local indication Electric transmitter HART communication	Local indication PROFIBUS PA	Local indication Electric transmitter Local integration Pulse output Alarm output	Local indication Alarm output

METER SIZE

15 mm to 150 mm or 1/2 inch to 6 inch

(Consult us for sizes of 200 mm or larger.)

See "AVAILABILITY OF CONNECTION SIZE" for available connection sizes corresponding to meter sizes.

Model	AM91LW	AM91E□ AM91H□	AM91P□	AM91T□	AM91N□	AM91R□	AM91M□
Function	Local indication	Electric transmission Electric transmission with HART communication	PROFIBUS PA	Local integration	Alarm output		
					Proximity switch	Reed switch	Micro switch
Meter size	15A to 150A				15A to 100A		

MATERIAL

304 SS, 316L SS

PRESSURE RATING

150lbs (10K) class, 300lbs (20K) class Consult TOKYO KEISO Co., Ltd. for higher pressure services.

See "AVAILABILITY OF CONNECTION" below for the standard rating.

OPERATING PRESSURE

4.1 MPa at room temperature

3.3 MPa at 120°C

The maximum operating pressure differs depending on fluid temperatures.

	Low pressure 150lbs (10K) class			Middle pressure 300lbs (20K) class		
	to 120	to 220	to 300	to 120	to 220	to 300
Max. Fluid Temp. (°C)	to 120	to 220	to 300	to 120	to 220	to 300
Max. Op. Press. (MPa)	1.4	1.2	1.0	3.4	3.1	2.9

See "FLUID TEMPERATURE" on page 4 for the operating temperature range.

CONNECTION

Standard flange connection

Low pressure	Standard JIS 10K RF	ANSI, JPI, DIN Other type are available
Middle pressure	Standard JIS 20K RF	

● AVAILABILITY OF CONNECTION SIZE

Notes for the following table

- * 1 A JIS 20K flange is used for a JIS 10K flange with a connection size of 15 to 40 mm. Both flanges have the same dimensions except that JIS 20K flanges are 2 mm thicker than JIS 10K flanges.
- * 2 For flanges with a nonstandard connection size marked by “Δ,” use stud bolts when mounting.
- * 3 Flanges with a nonstandard connection size marked by “x” are available if the face-to-face dimension is allowed to be 40 mm (meter size: up to 100) or 50 mm (meter size: 125 or more) longer than the standard length. Contact us for details.

10K、Class150						20K、Class300				
Connection rating	Meter size (mm)	Std. face-to-face dimension (L)	Standard	1-size up	2-size up	Connection rating	Meter size (mm)	Standard	1-size up	2-size up
10K	15	250	15*1	20*1	25*1	20K	15	15	20	25
	20	250	20*1	25*1	40*1		20	20	25	40
	25	250	25*1	40*1	50		25	25	40	50
	40	250	40*1	50	65		40	40	50	Δ65*2
	50	250	50	65	80		50	50	Δ65*2	×80*3
	65	250	65	80	100		65	Δ65*2	×80*3	×100*3
	80	250	80	100	Δ125*2		80	×80*3	×100*3	×125*3
	100	250	100	Δ125*2	Δ150*2		100	×100*3	×125*3	×150*3
	125	300	125	150	200		125	125	150	200
Class150	15	250	15	20	25	Class300	15	15	20	25
	20	250	20	25	40		20	20	25	Δ40*2
	25	250	25	40	50		25	25	Δ40*2	Δ50*2
	40	250	40	50	Δ65*2		40	Δ40*2	Δ50*2	×65*3
	50	250	50	Δ65*2	Δ80*2		50	Δ50*2	×65*3	×80*3
	65	250	Δ65*2	Δ80*2	Δ100*2		65	×65*3	×80*3	×100*3
	80	250	Δ80*2	Δ100*2	Δ125*2		80	×80*3	×100*3	×125*3
	100	250	Δ100*2	Δ125*2	Δ150*2		100	×100*3	×125*3	×150*3
	125	300	125	150	200		125	125	150	
150	300	150	200		150	150				

Note: Connection sizes must be at least the same size as the meter size.

● FLUID TEMPERATURE

Metallic material

Type	AM91□□	AM91□□/DU
Operating temperature range of fluid	-20 to 200 °C*	0 to 150 °C

* The range of -50 to 250°C is possible as option.

- ACCURACY Standard ±1.5 F.S. (On request ±1.0 F.S., Consult factory)
- STANDARD SCALE LENGTH 70 mm
- RANGEABILITY 10:1
- INDICATOR CONSTRUCTION Dust tight and water immersion proof IP67
- PAINTING COLOR

PAINTING	COLOR	
Indicator body	Jade green	Munsell 7.5BG4/1.5
Indicator cover. Transmitter	Light gray	Munsell N7.5

■ AM91□□ SERIES (LOCAL INDICATION)

- AMBIENT TEMPERATURE -30 to 80°C
- DIMENSION OF INDICATOR

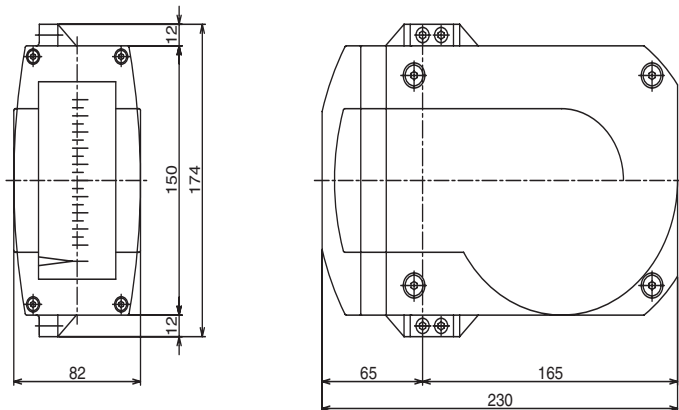

Approx. mass: 2.5kg

Fig. 1



AM91□□ /E□ SERIES (LOCAL INDICATOR WITH ELECTRIC TRANSMITTER)

AM91□□ /E□ indicates flow rate by pointer and scale plate, and outputs electric (4 to 20mA DC) signal which is proportional to flow rate. In addition to the dust tight and water immersion proof type, the intrinsically safe and flame proof versions.

● SPECIFICATION OF TRANSMITTER

Power supply voltage	: 10 to 30 V DC (Voltage between transmitter terminals) (For Intrinsically safe version : 10 to 28 V DC/For TIIS/KOSHA Flameproof version: 12 to 30 VDC)
Current output	: 4 to 20 mA DC (Effective output range : 4.0 to 21.6 mA At abnormal condition, however, 22.8 mA or 3.75 mA as an option can be output.)
Allowable load resistance	: Less than 830Ω (580Ω or less / 24 V DC) Determine the allowable load resistance for each supply voltage using following formula. Allowable load resistance \leq (Power supply voltage [V] - 10) / 0.024 [Ω] The allowable load resistance includes the one of circuit wiring.
Output accuracy	: $\pm 1.0\%$ F.S. (Against flow calibration)
Low cut off	: 0 to 20 %F.S. (default 7 %F.S.)
Damping	: 0 to 20 s (default 1 s)
Cable entry	: Weather proof 2-M20×1.5, 2-G1/2, 2-NPT1/2, Weather proof connector : Intrinsically safe & Flame proof 2-M20×1.5, 2-G1/2, 2-NPT1/2, Packing type cable gland Note : The packing type cable gland model SXC -16BY made by Shimada Electric Co. shall be used for the TIIS flame proof construction. The cable entry for the indicator is G 1/2 only.
Construction	: Dust tight and water immersion proof IP67 : Intrinsically safe Ex ia IIC T3 to T6 AM91□□ /E2/□ The temperature class of TIIS certified products is T6 (Certification is under examination). : Flame proof Ex d IIC T3 to T6 AM91□□/E1/□E The temperature class is T4 for TIIS, KOSHA Certified products
Ambient temp.	: Dust tight and water immersion proof -20 to 70 °C : Intrinsically safe -20 to 60 °C Ex ia IIC T3 to T6 : Flame proof -20 to 55 °C Ex d IIC T4 (For TIIS, KOSHA Certified products) -20 to 60 °C Ex d IIC T3 to T6 (For other certified products)
Insulation resistance	: 20 MΩ or more / 500V DC (between batch of power supply terminal and indicator case)
Withstand voltage	: 500 V AC/1 min (between batch of power supply terminal and indicator case)

● DIMENSION OF INDICATOR / TRANSMITTER

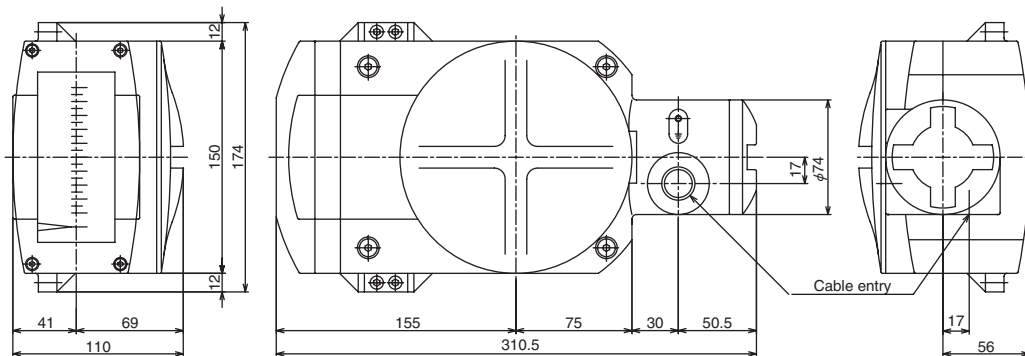

Approx. mass: 3.7 kg

Fig. 2

● TERMINAL AND WIRING

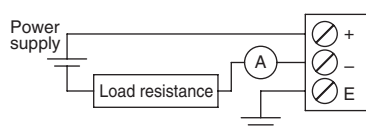

Fig. 3



AM91□□/H□ SERIES (LOCAL INDICATOR WITH ELECTRIC TRANSMITTER & HART COMMUNICATION)

AM91□□/H□ indicates flow rate by pointer and scale plate, and outputs electric (4 to 20mA DC) signal equipped with HART Communication complying with Multi-drop. In addition to the dust tight and water immersion proof type, the intrinsically safe and flame proof versions.

● SPECIFICATION OF TRANSMITTER

- Power supply voltage : 10 to 30 V DC (Voltage between transmitter terminals)
(For Intrinsically safe version: 10 to 28 V DC/For TIIS/KOSHA Flameproof version: 12 to 30 VDC)
- Current output : 4 to 20 mA DC
(Effective output range : 4.0 to 21.6mA At abnormal condition, however, 22.8mA or 3.75mA as an option can be output.)
- Allowable load resistance : 230 to 830Ω (Not less than 230Ω load resistance is needed for “with HART communication.”)
Determine the allowable load resistance for each supply voltage using following formula.
Allowable load resistance \leq (Power supply voltage [V] - 10) / 0.024 [Ω]
The allowable load resistance includes the one of circuit wiring.
- Output accuracy : $\pm 1.0\%$ F.S. (Against flow calibration)
- Low cut off : 0 to 20%F.S. (default 7% F.S.)
- Damping : 0 to 20s (default 1s)
- Cable entry : Weather proof 2-M20×1.5, 2-G1/2, 2-NPT1/2, Weather proof connector
: Intrinsically safe & Flame proof 2-M20×1.5, 2-G1/2, 2-NPT1/2, Packing type cable gland
Note : The packing type cable gland model SXC -16BY made by Shimada Electric Co. shall be used for the TIIS flame proof construction.
The cable entry for the indicator is G 1/2 only.
- Construction : Dust tight and water immersion proof IP67
: Intrinsically safe Ex ia IIC T3 to T6 AM91□□/E2/□
The temperature class of TIIS certified products is T6 (Certification is under examination.)
: Flame proof Ex d II T3 to T6 AM91□□/H1/□E
The temperature class is T4 for TIIS, KOSHA Certified products
- Ambient temp. : Dust tight and water immersion proof -20 to 70°C
: Intrinsically safe -20 to 60°C Ex ia IIC T3 to T6
: Flame proof -20 to 55°C Ex d IIC T4 (For TIIS, KOSHA Certified products)
-20 to 60°C Ex d IIC T3 to T6 (For other certified products)
- Insulation resistance : 20 MΩ or more/500V DC (between batch of power supply terminal and indicator case)
- Withstand voltage : 500V AC/1min (between batch of power supply terminal and indicator case)

● DIMENSION OF INDICATOR / TRANSMITTER

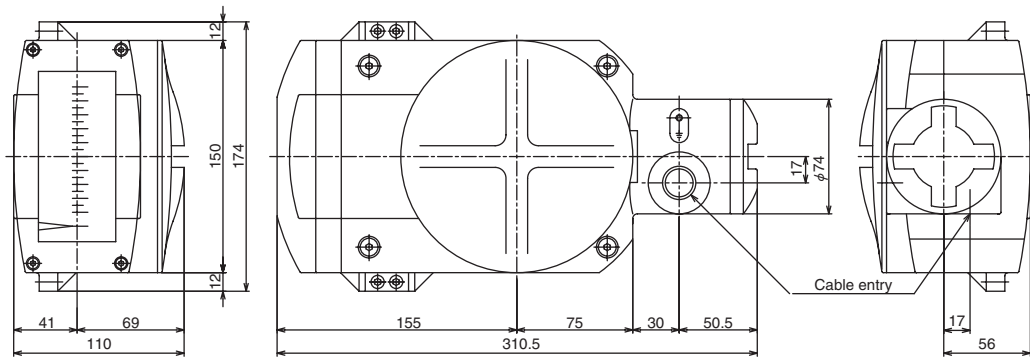

Fig. 4

Approx. mass: 3.7 kg

● TERMINAL AND WIRING



Fig. 5



AM91□□/P□ SERIES (LOCAL INDICATOR WITH 2-WIRE PROFIBUS PA COMMUNICATION)

AM91□□/P□ indicates flow rate by pointer and scale plate, and PROFIBUS PA Communication for process automation. In addition to the dust tight and water immersion proof type, the intrinsically safe and flame proof versions.

● SPECIFICATION OF TRANSMITTER

Power supply voltage	: Bus power supply 10 to 32 V DC
	However, the power supply for the intrinsically safe circuit with the safety barrier, and with FISCO system is 10 to 24 V DC, and 10 to 17.5 V DC respectively.
BUS Communication	Base current : less than 12mA
	In/output signal : Manchester-coded Bus Powered (IEC 61158-2)
	Communication protocol : PROFIBUS DP-V1
	Device · profile : PROFIBUS PA Profile V3.01
	Function block : 1 Analog Input for volume (or mass) flow rate 1 Totalizer for volume (or mass) flow counter
Output accuracy	: ±1.0 % F.S. (Against flow calibration)
Cable entry	: Weather proof 2-M20×1.5, 2-G1/2, 2-NPT1/2, Weather proof connector
	: Intrinsically safe & Flame proof 2-M20×1.5, 2-G1/2, 2-NPT1/2, Packing type cable gland
	Note : The packing type cable gland model SXC -16BY made by Shimada Electric Co. shall be used for the TIIS flame proof construction.
	The cable entry for the indicator is G 1/2 only.
Construction	: Dust tight and water immersion proof IP67
	: Intrinsically safe Ex ia IIC T3 to T6 AM91□□/P2□ I
	The temperature class of TIIS certified products is T6 (Certification is under examination).
	: Flame proof Ex d IIC T3 to T6 AM91□□/P1□ E
	The temperature class is T4 for TIIS, KOSHA certified products (KOSHA certification is under examination.)
Ambient temp.	: Dust tight and water immersion proof -20 to 70 °C
	: Intrinsically safe -20 to 60 °C Ex ia IIC T3 to T6
	: Flame proof -20 to 55 °C Ex d IIC T4 (For TIIS, KOSHA Certified products)
	-20 to 60 °C Ex d IIC T3 to T6 (For other certified products)
Insulation resistance	: 20 MΩ or more/500 V DC (between batch of power supply terminal and indicator case)
Withstand voltage	: 500 V AC/1 min (between batch of power supply terminal and indicator case)

● DIMENSION OF INDICATOR / TRANSMITTER

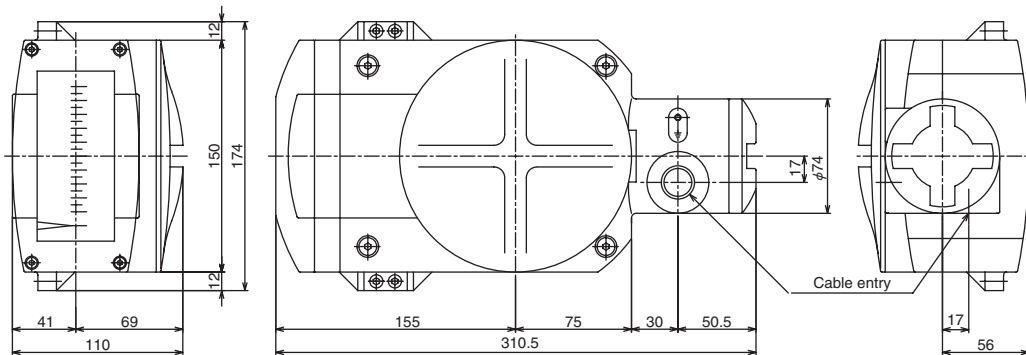

Approx. mass: 3.7 kg

Fig. 6

● TERMINAL AND WIRING

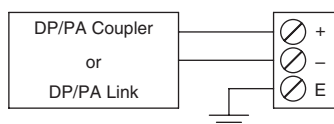

Fig. 7



AM91□□/T□ SERIES (LOCAL INDICATOR WITH LOCAL INTEGRATION, INTEGRATION PULSE, ELECTRIC TRANSMISSION AND HART COMMUNICATION)

With local flow rate indication, AM91□□/T□ has the functions of local flow integration, integration pulse output, 4 to 20mA electric output and Hart communication. This series serves the custody of flow. The additional magnetic sensing switches to conventional push buttons are available for customers' convenience. In addition to the dust tight and water immersion proof type, and the flame proof version.

● SPECIFICATION OF TRANSMITTER

- Integration : 6 digit red LCD (With 8 digit scaling and reset function)
- Count rate : Less than 10 Hz (Less than 36000 c/h)
- Pulse or Alarm output : NPN Open collector 2 point select output (Pulse width : 30 ms, 50 ms, 100 ms, 200 ms, 500 ms)
: 1 point alarm + pulse output, or 2 points alarm output (Alarms are selectable from the flow rate or the integrated flow alarm.)
: Max. voltage 30 V DC, max. current 50 mA
(The power supply circuit and the output circuit are insulated.)
Reverse-connected protection, Residual voltage when turning it on more less 1.2 V (10 mA)
- Integration accuracy : ±1.0 %F.S. (Against flow calibration)
- Power supply : 16 to 30 V DC (Voltage between transmitter terminals)
- Current consumption : Less than 60 mA
- Current output : 4 to 20mA DC
(Effective output range : 4.0 to 21.6 mA At abnormal condition, however, 22.8 mA or 3.75 mA as an option can be output.)
- Allowable load resistance : Less than 830Ω (In case of HART communication version : 230 to 830Ω)
Determine the allowable load resistance for each supply voltage using following formula.
Allowable load resistance ≅ (Power supply voltage [V] - 10) / 0.024 [Ω]
The allowable load resistance includes the one of circuit wiring.
- Output accuracy : ±1.0 %F.S.(Against flow calibration)
- Low cut off : 0 to 20 %F.S. (default 7%F.S.)
- Damping : 0 to 20 s (default 1s)
- Cable entry : 2-G3/4, 2-NPT3/4, Packing type cable gland
Note : The packing type cable gland model SXC -22BY made by Shimada Electric Co. shall be used for the TIIS flame proof construction.
The cable entry for the indicator is G 3/4 only.
- Construction : Dust tight and water immersion proof IP67
: Flame proof Ex d II T3 to T6 AM91□□/T□□E
The temperature class is T4 for TIIS, KOSHA certified products
- Ambient temp. : Dust tight and water immersion proof -20 to 70 °C
: Flame proof -20 to 55 °C Ex d IIC T4 (For TIIS, KOSHA Certified products)
-20 to 60 °C Ex d IIC T3 to T6 (For other Certified products)
- Insulation resistance : 20 MΩ or more/500 V DC
(between batch of power supply terminal and indicator case)
- Withstand voltage : 500 V AC/1min
(between batch of power supply terminal and indicator case)

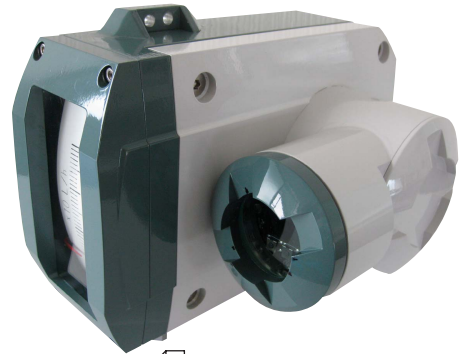

● DIMENSION OF INDICATOR

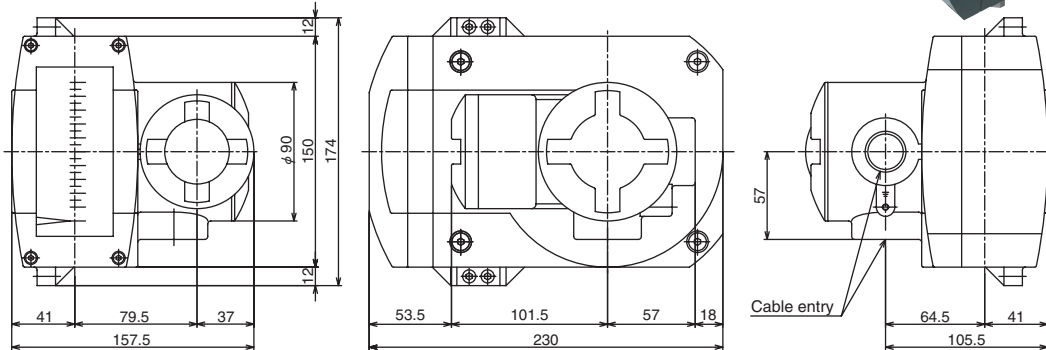

Approx. mass: 3.8 kg

Fig. 8

● TERMINAL AND WIRING

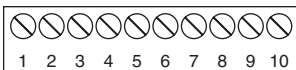

Terminal No.	1	2	3	4	5	6	7	8	9	10
Terminal wiring	DO1+	DO1-	DO2+	DO2-		R+	R-	PS+	PS-	FG

Fig. 9

(Attention) DO: Contact output terminals, R: 4-20 mA analog output terminals, PS: Power supply, FG: Grounding

AM91□□/R□ SERIES (LOCAL INDICATOR WITH REED SWITCH TYPE ALARM)

AM91□□/R□ indicates flow rate by pointer and outputs SPST contact at set point for flow alarm.
In addition to the dust tight and water immersion proof type, and the intrinsically safe version.

● SPECIFICATION OF TRANSMITTER

- Alarm point : 2 points (1 point high alarm, 1 point low alarm or 2 points high and low alarm)
- Switch : Reed switch (a or b contact)
- Rating : Reed switch (SPST) 10 VA AC, 10 W DC as resistance load
Max. 125 V AC/0.5 A, Max. 100 V DC/0.5A
- Setting accuracy : ±1.5 % F.S. (Against flow calibration)
Note: While switch is on, and if any other flow rate than the alarm setting value is indicated, it result in causing wrong
- Reset span : Less than 15 % F.S. (Against flow calibration)
- Cable entry : G1/2 or NPT1/2 or others
- Enclosure : Dust tight and water immersion proof IP67
: Intrinsically safe To be used in combination with the safety barrier provided by customers.
See page 12 for details.
- Ambient temp. : Dust tight and water immersion proof -20 to 80 °C
: Intrinsically safe -20 to 60 °C subject to the safety barrier.
- Insulation resistance : 100 MΩ or more/500 V DC (between batch of power supply terminal and indicator case)
- Withstand voltage : 1500 V AC/1min (between batch of power supply terminal and indicator case)

● DIMENSION OF INDICATOR / TRANSMITTER

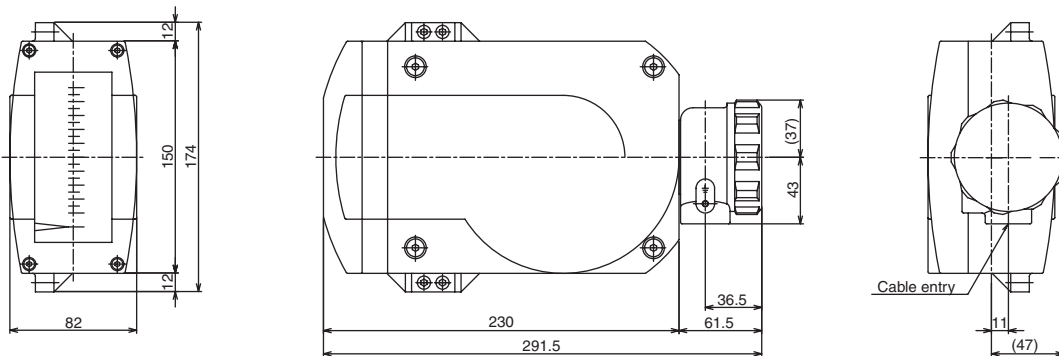

Approx. mass: 2.8 kg

Fig. 10

● TERMINAL AND WIRING

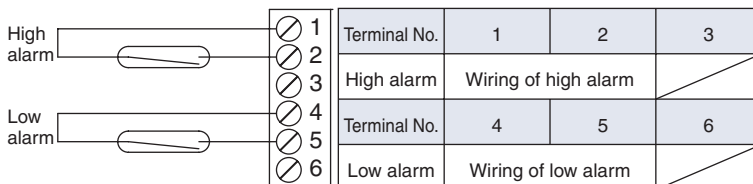

Fig. 11

Note : Terminal No.4 and 5 are not used for 1 point high alarm. Likewise, terminal No. 1 and 2 are not used for 1 point low alarm.



AM91□□/N□ SERIES (LOCAL INDICATOR WITH PROXIMITY SWITCH TYPE ALARM)

With local flow rate indication, AM7□□□/N□ series has a proximity switch which outputs alarm signals complying with NAMUR standard. In addition to the dust tight and water immersion proof type, the intrinsically safe version is under examination for certification.

● SPECIFICATION OF TRANSMITTER

- Alarm point : 2 points (1 point high alarm, 1 point low alarm or 2 points high and low alarm)
- Switch : Proximity switch
- Power supply voltage : 8 V DC
- Operating current : Proximity switch complying with NAMUR, ON :1mA or less, OFF : 3 mA or more
- Setting accuracy : ±1.5 % F.S. (Against flow calibration)
- Reset span : Less than 1.5 % F.S. (Against flow calibration)
- Cable entry : G1/2 or NPT1/2 or others
- Enclosure : Dust tight and water immersion proof IP67
 - : Intrinsically safe To be used in combination with the safety barrier provided by customers.
 - See page 12 for details.
- Ambient temp. : Dust tight and water immersion proof -25 to 80 °C
 - : Intrinsically safe -20 to 60 °C subject to the safety barrier.
- Insulation resistance : 100 MΩ or more/500 V DC (between batch of power supply terminal and indicator case)
- Withstand voltage : 500 V DC/1min (between batch of power supply terminal and indicator case)

● DIMENSION OF INDICATOR / TRANSMITTER

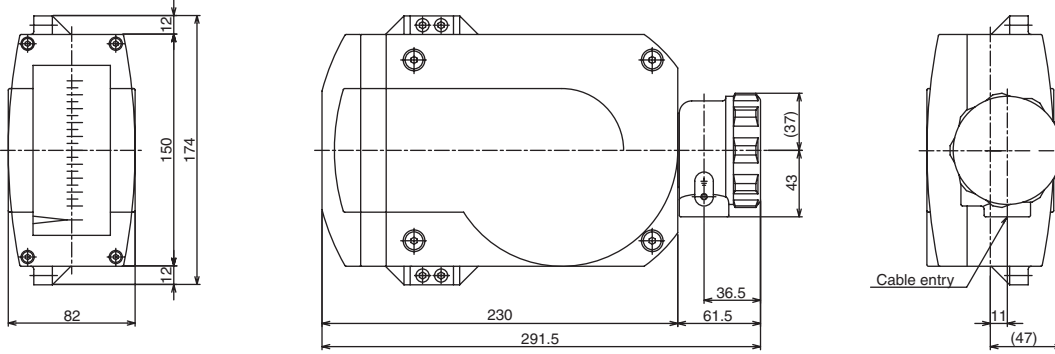

Approx. mass: 2.8 kg

Fig. 12

● TERMINAL AND WIRING

1	Terminal No.	1	2	3
2	High alarm	+	-	
3				
4	Terminal No.	4	5	6
5				
6	Low alarm	+	-	

Fig. 13 Note : Terminal No.4 and 5 are not used for 1 point high alarm. Likewise, terminal No. 1 and 2 are not used for 1 point low alarm.



AM91□□/M□ SERIES (LOCAL INDICATOR WITH MICRO SWITCH TYPE ALARM)

With local flow rate indication, AM91□□/M□ series has a micro switch which outputs SPDT alarm signals. In addition to the dust tight and water immersion proof type, and the intrinsically safe version.

● SPECIFICATION OF TRANSMITTER

- Alarm point : 2 points (1 point high alarm, 1 point low alarm or 2 points high and low alarm)
- Switch : Micro switch (c contact)
- Rating : 250 V AC/5A as resistance load
- Setting accuracy : ±1.5 % F.S. (Against flow calibration)

Note: While switch is on, and if any other flow rate than the alarm setting value is indicated, it may result in causing wrong accuracy.

- Reset span : (meter size 15-80 mm): Less than 25% F.S. (Less than 35% F.S. for the 2-point alarm)
(meter size 100 mm): Less than 30% F.S. (Less than 40% F.S. for the 2-point alarm)

- Cable entry : G1/2 or NPT1/2 or others

- Enclosure : Dust tight and water immersion proof IP67
: Intrinsically safe To be used in combination with the safety barrier provided by customers.
See page 12 for details.

- Ambient temp. : Dust tight and water immersion proof -25 to 80 °C
: Intrinsically safe -20 to 60 °C subject to the safety barrier.

Insulation resistance : 100 MΩ or more/500 V DC (between batch of power supply terminal and indicator case)

Withstand voltage : 1500 V AC/1 min (between batch of power supply terminal and indicator case)

● DIMENSION OF INDICATOR / TRANSMITTER

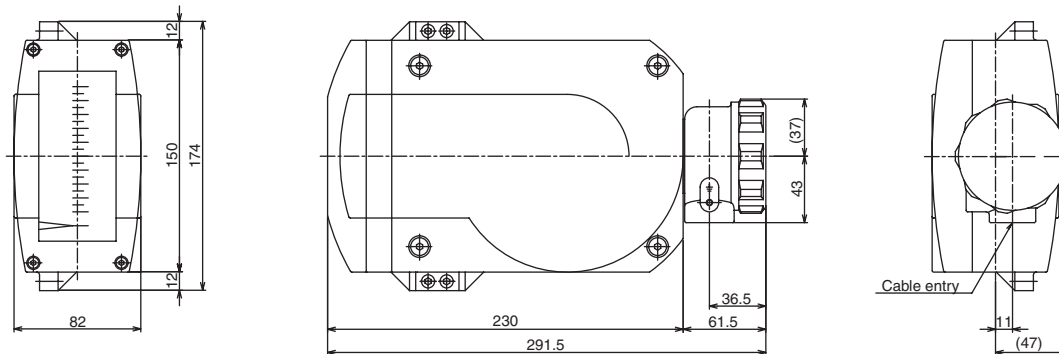

Approx. mass: 2.8 kg

Fig. 14

● TERMINAL AND WIRING

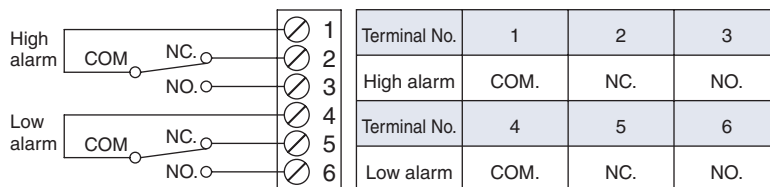

Fig. 15

Note : Terminal No.4, 5,6 are not used for 1 point high alarm. Likewise, terminal No. 1,2,3 are not used for 1 point low alarm.



AM91□□/□□/□ E SERIES (FLAMEPROOF VERSION)

Flameproof models complying with the standard are available depending on additionally specified features of the current transmission, PROFIBUS PA, or local integration.

Ex type	Class	Functions				
		Current transmission	Current transmission HART communication	PROFIBUS PA communication	Local integration	Alarm output
TIIS	Ex d IIC T4	○	○	○	○	-
KOSHA	Ex d IIC T4	○	○	-	○	-
NEPSI	Ex d IIC T3~T6 Gb	○	○	○	○	-
ATEX	II2 G Ex d IIC T6... T3	○	○	○	○	-
IECEX	Ex d IIC T6... T3 Gb	○	○	○	○	-

Note: Be sure to use the cable gland shown in the figure below for the TIIS flameproof version (current transmission, current transmission HART communication, PROFIBUS PA communication, or local integration).

For the current transmission, current transmission HART communication, and PROFIBUS PA communication:

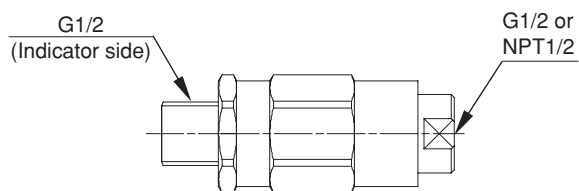

SXC-16BY by Shimada Electric Co.

For the local integration

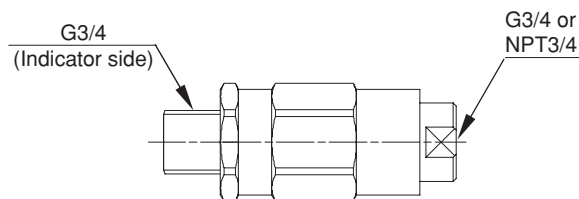

SXC-22BY by Shimada Electric Co.

AM91□□/□□/□ I SERIES (INTRINSICALLY SAFE VERSION)

Intrinsically safe models complying with the standard are available depending on additionally specified features of the current transmission, PROFIBUS PA, or alarm output.

Ex type	Class	Functions				
		Current transmission	Current transmission HART communication	PROFIBUS PA communication	Local integration	Alarm output
TIIS	Ex ia IIC T6	○	○	-	-	(Under examination)
KOSHA	Ex ia IIC T3... T6	-	-	-	-	-
NEPSI	Ex ia IIC T3~T6 Gb	○	○	○	-	○
ATEX	II2 G Ex ia IIC T3... T6 Gb	○	○	○	-	○

Note: The reed switch type (AM91___/R_) and the micro switch type (AM91___/M_) are available only when the intrinsically safe relay barrier is used. The proximity switch type is pending the certification. Consult us for details.

● INTRINSICALLY SAFE SPECIFICATION OF CURRENT TRANSMISSION AND PROFIBUS PA COMMUNICATION

	Current transmission (AM91□/E2/□I)	PROFIBUS PA communication (AM91□/P2/□I)	
		Safety retainer	FISCO power supply
Max. voltage for intrinsically safe circuit	28 V DC	24 V DC	17.5 V DC
Max. current for intrinsically safe circuit	93 mA	150 mA	400 mA
Max. power consumption for intrinsically safe circuit	650 mW	1.2 W	5.4 W
Capacitance inside intrinsically safe circuit	5 nF	3 nF	3 nF
Inductance inside intrinsically safe circuit	0.2 mH	0 mH	0 mH

● INTRINSICALLY SAFE SPECIFICATION OF ALARM OUTPUT

	Reed switch (AM91□/R□/□I)	Proximity switch (AM91□/N□/□I)	Micro switch (AM91□/M□/□I)
Max. voltage for intrinsically safe circuit	30 V DC	16 V DC	30 V DC
Max. current for intrinsically safe circuit	500 mA	25 mA	500 mA
Max. power consumption for intrinsically circuit	—	64 mW	—
Capacitance inside intrinsically safe circuit	—	150 nF	—
Inductance inside intrinsically safe circuit	—	150 μH	—
Recommended relay barrier	EB3C (IDEC)	KFD2-SR2-Ex.1W (P&F)	EB3C (IDEC)

■ ADDITIONAL FUNCTION

● GAS DAMPER (Model AM91□□/DU)

All flowmeters with their meter sizes ranging from 15 to 100 mm for gas measurement are equipped with gas dampers as standard.

Mechanical damper is integrated at the part of float guide which consists of piston and cylinder. As it is not required to install liquid damper at the bottom of flowmeters, it contributes to increase the flexibility of piping design. Also it is not required to fill damper liquid that saves maintenance labour works.

Gas damper is applicable for gas and steam measurement applications and not suitable for liquids. Also chlorine gas (easy to form chemical compound) and gas containing rust, trash and oil may hinder the function of piston part.

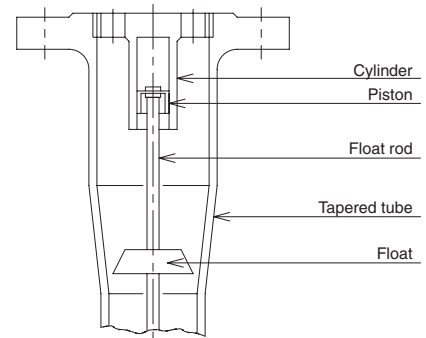

Fig. 16

■ DIMENSIONS, MATERIAL, PRESSURE DROP, FLOW RATE TABLE

The mass in the following tables shows the one of the type with a local indicator only. See the each item "DIMENSION INDICATOR/ TRANSMITTER" with the individual transmitter for its dimensions and mass.

● Model AM91□□ (Flow direction Bottom to Top)

Measuring fluids : Liquids

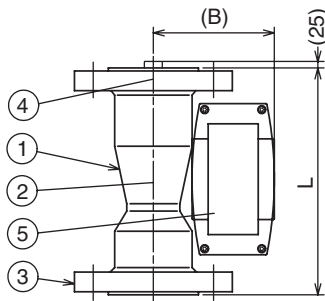

Fig. 17

■ Table 1

Meter size	Flow rate of water (m ³ /h)	Pressure loss (kPa)	10K, Class 150		
			L (mm)	(B) (mm)	Mass (kg)
15	0.035 to 1.4 ^{*1}	4.5	250	95	4.7
20	2.8	10	250	97	5.1
25	6.2	12.5	250	104	6.8
40	16	11	250	111	8.4
50	24	8	250	120	9.5
65	34	11	250	130	12.0
80	52	9	250	136	13.1
100	100	10	250	149	16.3
125	150	25	300	161	21.3
150	200	21	300	177	28.6

*1 0.1 to 1.4 m³/h for the micro switch type (AM91□□/M□).

*2 The float rod comes out 20 mm during operation in the case of flowmeters with a meter size from 100 mm to 150 mm.

■ Table 2

No.	Description	Material class 2	Material class 3	Material class 4
1	Tapered tube	SCS16/316L SS	—	SCS16/316L SS
2	Float assembly	316L SS	—	316L SS
3	Flange	304 SS	—	316L SS
4	Float guide	SCS16/316L SS	—	SUS16/316L SS
5	Indicator	ADC12	—	ADC12

● Model AM91□□/DU (Flow direction Bottom to Top with gas damper)

Measuring fluids : Gases and Steam

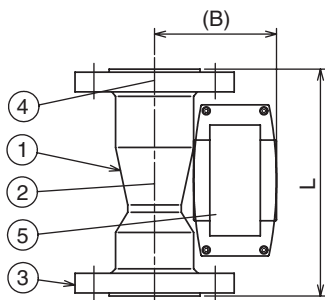

Fig. 18

■ Table 3

Meter size	Flow rate of air [m ³ /h(nor)]	Pressure loss (kPa)	Dimension(mm)		Mass (kg)/JIS10K
			L	B	
15	1~40 ^{*1}	44	250	95	4.8
20	81	21	250	97	5.1
25	168	24	250	104	6.8
40	316	15	250	111	8.3
50	540	15	250	120	9.5
65	866	11	250	130	11.8
80	1192	8	250	136	12.8
100	1723	12	250	149	16.2

*1 3 to 40 m³/h (nor) for the micro switch type (AM91□□/M□).

■ Table 4

No.	Description	Material class 2	Material class 3	Material class 4
1	Tapered tube	SCS16/316L SS	—	SCS16/316L SS
2	Float assembly	316L SS/MA276	—	316L SS/MA276
3	Flange	304 SS	—	316L SS
4	Float guide	SCS16/316L SS	—	SCS16/316L SS
5	Indicator	ADC12	—	ADC12

SELECTION OF FLOWMETER

1. LIQUID APPLICATION

a. Selection of meter size

The maximum flow rate of each meter size is shown in "DIMENSIONS, MATERIAL, PRESSURE DROP, FLOW RATE TABLE." These figures are based on water flow (Density 1.0g/cm³ and Viscosity 1.0MPa·s). If actual fluid condition is different from such figures, a conversion calculation is required as following formula:

$$Q_w = Q \times 2.59 / \sqrt{(7.7/\rho) - 1}$$

Q_w : Water converted flow rate (m³/h)

Q : Flow rate of actual fluid (m³/h)

ρ : Density of actual fluid (g/cm³)

Example Fluid: Alcohol Density: 0.8g/cm³
 Flow rate: 50m³/h Flowmeter to be used: AM91□□

$$\begin{aligned} Q_w &= 50 \times 2.59 / \sqrt{(7.7/0.8) - 1} \\ &= 50 \times 0.882 \\ &= 44.1 \text{ m}^3/\text{h} \end{aligned}$$

You will find required meter size to be 80 mm which covers above converted flow rate from table 1. Please refer to "AVAILABILITY OF CONNECTION SIZE" for the possible connection size applied for the required meter size.

Consult TOKYO KEISO Co., Ltd. for high viscosity services.

b. Slurry application

For slurry services such as liquids containing precipitates, particles, sands, the flowmeters suitable for slurry liquids are available. Consult TOKYO KEISO Co., Ltd. for details.

2. GAS APPLICATION

Use the flowmeter with a gas damper unless otherwise specified to avoid a hunting, model AM91□□/DU.

Selection of meter size

The maximum flow rate of each meter size AM91□□/DU is shown at the measuring conditions of 0°C, 1 atm air of its density 1.293 kg/m³ nor. in "DIMENSIONS, MATERIAL, PRESSURE DROP, FLOW RATE TABLE."

If actual fluid condition is different from such figures, a conversion calculation is to be performed by the following formula:

$$Q_A = Q \times 0.01635 \times \sqrt{\rho \times (273+t) / (0.1013+p)}$$

Q_A : Converted flow rate in air 0°C, 1atm [m³/h(nor)]

Q : Flow rate of gas to be measured [m³/h(nor)]

ρ : Density of gas to be measured [kg/m³(nor)]

p : Density of gas to be measured (MPa)

t : Operating temperature (°C)

Example Gas to be measured : Nitrogen (N₂) Density (ρ) : 1.251kgf/m³(nor)
 Operating pressure (p) : 0.6MPa Operating temperature (t) : 20°C
 Flow rate of gas to be measured (Q) : 300 m³/h(nor)
 Flowmeter with a gas damper to be used : AM91□□/DU

$$\begin{aligned} Q_A &= 300 \times 0.01635 \times \sqrt{1.251 \times (273+20) / (0.1013+0.6)} \\ &= 300 \times 0.01635 \times 22.86 \\ &= 112.1 \text{ m}^3/\text{h (nor)} \end{aligned}$$

You will find required meter size to be 25 mm which covers above converted flow rate from table 3. Please refer to "AVAILABILITY OF CONNECTION SIZE" for the possible connection size applied for the required meter size.

3. STEAM APPLICATION

Use the flowmeter with a gas damper unless otherwise specified to avoid a hunting, model AM91□□/DU.

Selection of meter size

Steam flow rate is to be converted into air flow rate by the following formula for size determination.

$$Q_A = Q_S \times 0.849 \times \sqrt{\rho}$$

Q_A : Air flow rate at 0°C, 1 atm converted from steam [m³/h(nor)]

Q_S : Steam flow rate (m³/h)

ρ : Density of steam (kg/m³)

Example Fluid : Saturated steam Pressure : 0.9MPa
 Flow rate : 1t/h Flowmeter with a gas damper to be used : AM91□□/DU

First, density of the steam is to be obtained from "Steam graph" etc. In this application, density(ρ) of 0.9MPa steam is 5.1kg/m³. Saturated steam curve (by temperature) is shown on Fig. 19 and saturated steam curve (by pressure) is on Fig. 20 for reference. Normally, flow rate of steam is described in weight unit, which is to be converted to volume unit (Q_S) as follows:

$$1t/h = 1000 \text{ kg/h}$$

$$Q_S = 1000 \text{ kg/h} / 5.1 \text{ kg/m}^3 = 196 \text{ m}^3/h$$

Then, all these figures are to be put into the formula:

$$Q_A = 196 \times 0.849 \times \sqrt{5.1}$$

$$= 196 \times 1.917$$

$$= 376 \text{ m}^3/h \text{ (nor)}$$

You will find required meter size to be 50 mm which covers above converted flow rate from table 3. Please refer to "AVAILABILITY OF CONNECTION SIZE" for the possible connection size applied for the required meter size.

● Density of saturated Steam(by temperature)

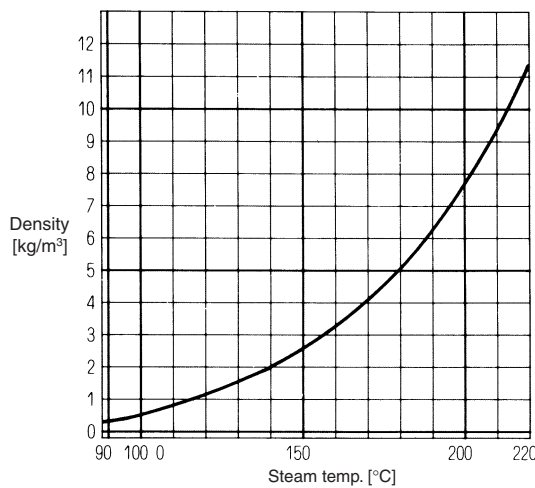

Fig. 19

● Density of saturated Steam (by pressure)

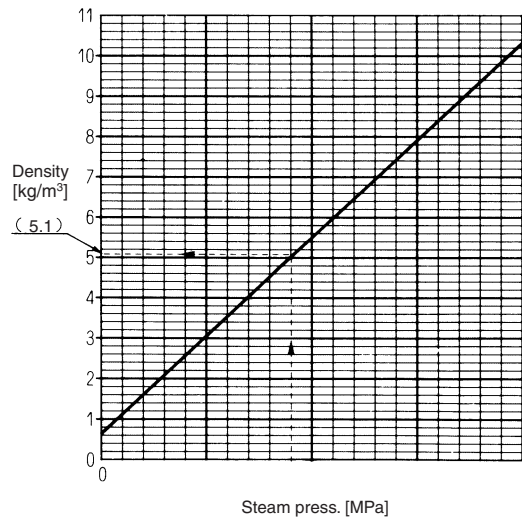

Fig. 20

4. SCALE GRADUATION

Customers can select the scale graduations of which maximum flow rate is between maximum flow rate of the chosen meter size and the one of one-rank-smaller meter size from the following 16 kinds of standard graduations. The range of graduations, rangeability is 10 : 1.

Example If required scale range is 35–350 m³/h (nor), the graduation on the flowmeter will be 3.5 ~ 35×10 m³/h (nor)

● Standard scale graduation

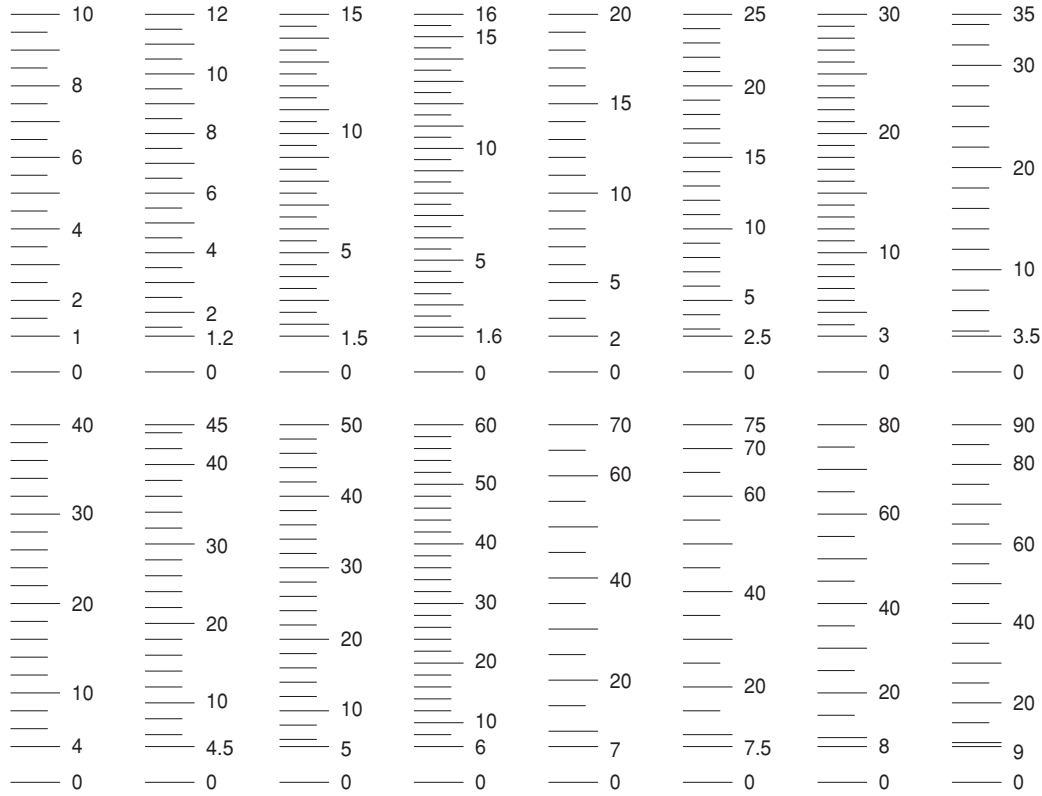

5. SPECIAL ORDERS

a. Low pressure drop version

If standard pressure drop does not meet the requirement, "Low pressure drop version" from AM7000 series is available on request. Consult TOKYO KEISO Co., Ltd. for further details.

b. Low temperature application

If the fluid temperature is very low (i.e. liquefied gas etc.), Special arrangement to prevent frost from AM7000 series is available. Consult TOKYO KEISO Co., Ltd. for further details.

c. High pressure application

TOKYO KEISO Co., Ltd. has the manufacturing record of max. 196 MPa from AM7000 series. Contact us.

■ CAUTIONS

- This flowmeter transmits the displacement caused by the magnet coupling. A surrounding magnetic field might affect its performance.
- Avoid installation near magnetic fields. Magnetic materials including insulation covers may also affect its performance; do not bring them within 20 cm from the flowmeter.
- When installing two or more flowmeters, place them at least the distances shown in Fig. 21 to Fig. 23 apart from each other to avoid mutual interference.

For maintenance, ensure a clearance of at least 20 cm between the indicator of one flowmeter and the body of other flowmeters.

Local indication and alarm output type

For a meter size of 50 mm or less: at least 35 cm
For a meter size of 65 mm or more: at least 45 cm

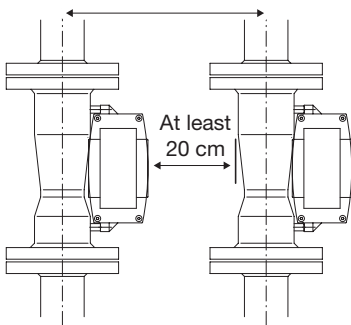

Fig. 21

Electric transmitter and PROFIBUS PA type

For a meter size of 50 mm or less: at least 35 cm
For a meter size of 65 mm or more: at least 45 cm

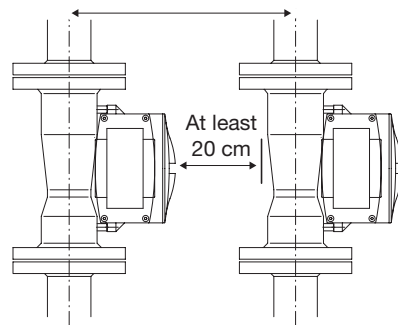

Fig. 22

Local integration type

For a meter size of 50 mm or less: at least 40 cm
For a meter size of 65 mm or more: at least 50 cm

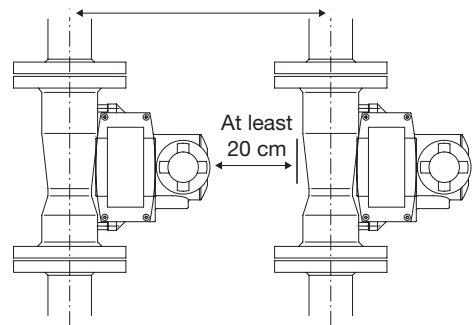

Fig. 23

* Specification is subject to change without notice.

***TIV* TOKYO KEISO CO., LTD.**

Head Office : Shiba Toho Building, 1-7-24 Shibakoen, Minato-ku, Tokyo 105-8558

Tel : +81-3-3431-1625 (KEY) ; Fax : +81-3-3433-4922

e-mail : overseas.sales@tokyokeiso.co.jp ; URL : <http://www.tokyokeiso.co.jp>



ISO 9001 Certified
JQA-2172